

BRIDGE AND ROOF CO. (INDIA) LIMITED

NOTICE INVITING TENDER (NIT) No.:B AND R/51110/TD/SC/RCC ROAD WORK/01 DTD. 13/06/2024

BIDDING DOCUMENT

FOR

EXECUTION OF RCC ROAD ALONG WITH FOOTPATH, DRAINAGE AND MISCELLANEOUS FINISHING WORK ON SUB-CONTRACT BASIS IN CONNECTION WITH "CONSTRUCTION OF NEW ISLAND PLATFORM AND REFURBISHING OF EXISTING PLATFORMS INCLUDING PLATFORM SHADE AT SANTRAGACHI RAILWAY STATION REGARDING STATION DEVELOPMENT WORK FOR SOUTH EASTERN RAILWAY IN WEST BENGAL.



BRIDGE AND ROOF CO. (INDIA) LIMITED
Santragachi Station Development Work site,
1st Floor, New Station Building, Platform No. 6
Santragachi, PIN- 711 111, West Bengal

Document Fee: Rs. 5,000.00 + GST(Non-Refundable)

BRIDGE AND ROOF CO. (INDIA) LIMITED
 Santragachi Station Development Work site,
 1st Floor, New Station Building, Platform No. 6
 Santragachi, PIN- 711 111, West Bengal
 CIN No.: U27310WB1920GOI003601

NOTICE INVITING TENDER (NIT) No.:B AND R/51110/TD/SC/RCC ROAD WORK/01 DTD. 13/06/2024

EXECUTION OF RCC ROAD ALONG WITH FOOTPATH, DRAINAGE AND MISCELLANEOUS FINISHING WORK ON SUB-CONTRACT BASIS IN CONNECTION WITH “CONSTRUCTION OF NEW ISLAND PLATFORM AND REFURBISHING OF EXISTING PLATFORMS INCLUDING PLATFORM SHADE AT SANTRAGACHI RAILWAY STATION REGARDING STATION DEVELOPMENT WORK FOR SOUTH EASTERN RAILWAY IN WEST BENGAL.

MASTER INDEX

QUALIFYING CRITERIA	:	ANNEXURE – I
INSTRUCTIONS TO BIDDERS (ITB)	:	ANNEXURE – II
GENERAL CONDITIONS OF CONTRACT	:	ANNEXURE – III
SPECIAL CONDITIONS OF THE CONTRACT	:	ANNEXURE – IV
SCHEDULE OF QUANTITIES & RATES	:	ANNEXURE – V
TECHNICAL SPECIFICATION	:	ANNEXURE – VI
SAFETY PRECAUTIONS	:	ANNEXURE – VII
TENDER DRAWINGS	:	ANNEXURE – VIII
FORMATS	:	
LETTER OF SUBMISSION	:	ANNEXURE- II(A)
DETAIL OF INFORMATION TO BE FURNISHED BY THE BIDDER	:	ANNEXURE- II(B)
NO DEVIATION CERTIFICATE	:	ANNEXURE- II(C)
CERTIFICATE OF DECLARATION FOR CONFIRMING THE KNOWLEDGE OF SITE CONDITIONS	:	ANNEXURE- II(D)
DECLARATION AGAINST TECHNICAL SPECIFICATION	:	ANNEXURE – II(E)
DETAILS OF WORK IN HAND AND WORKS EXECUTED	:	ANNEXURE - H
DEPLOYMENT SCHEDULE OF CONSTRUCTION EQUIPMENT	:	ANNEXURE- I
DEPLOYMENT SCHEDULE OF SUPERVISORY PERSONNEL	:	ANNEXURE- J
AFFIDAVIT IN NON – JUDICIAL STAMP PAPER CERTIFIED BY NOTARY PUBLIC OR 1ST CLASS MAGISTRATE	:	ANNEXURE - K
BANK GUARANTEE IN LIEU OF SECURITY CUM PERFORMANCE	:	ANNEXURE- L
PURCHASE PREFERENCE TO MAKE IN INDIA	:	ANNEXURE- M

SHARES A LAND BORDER	:	ANNEXURE - N
INPUT TAX CREDIT FORMAT	:	ANNEXURE - O
DETAILS OF TECHNICAL AND ADMINISTRATIVE PERSONNEL TO BE EMPLOYED FOR THE WORK	:	ANNEXURE - P
DETAILS OF CONSTRUCTION PLANT AND EQUIPMENT LIKELY TO BE USED IN CARRYING OUT THE WORK	:	ANNEXURE - Q
INFORMATION REGARDING CURRENT LITIGATION, DEBARRING EXPELLING OF BIDDER OR ABANDONMENT OF WORK BY THE BIDDER	:	ANNEXURE - R
PREAMBLE TO SCHEDULE OF QUANTITIES and RATES	:	ANNEXURE - R1
COMPLIANCE TO BID REQUIREMENT	:	ANNEXURE - S
DECLARATION BY BIDDER	:	ANNEXURE - T
BANK GUARANTEE IN LIEU OF EARNEST MONEY DEPOSIT	:	ANNEXURE - U
BANK GUARANTEE IN LIEU OF SECURITY DEPOSIT	:	ANNEXURE - W

BRIDGE AND ROOF CO. (INDIA) LIMITED

NOTICE INVITING TENDER (NIT) No.:B AND R/51110/TD/SC/RCC ROAD WORK/01 DTD. 13/06/2024

NAME OF WORK

EXECUTION OF RCC ROAD ALONG WITH FOOTPATH, DRAINAGE AND MISCELLANEOUS FINISHING WORK ON SUB-CONTRACT BASIS IN CONNECTION WITH "CONSTRUCTION OF NEW ISLAND PLATFORM AND REFURBISHING OF EXISTING PLATFORMS INCLUDING PLATFORM SHADE AT SANTRAGACHI RAILWAY STATION REGARDING STATION DEVELOPMENT WORK FOR SOUTH EASTERN RAILWAY IN WEST BENGAL.

Sl. No.	Technical Cover Details	Documents
1.	Cover-I	i) Tender fee ii) Earnest Money Deposit (EMD) iii) MSME Notarized copy of Valid Registration Certificate and Affidavit Cum Declaration for MSME registered parties iv) Power of Attorney, on stamp paper of appropriate value, v) Process Compliance Form and Letter of Submission (in Company's letter head), vi) No Deviation Certificate in Bidder's letter head, vii) Detail of information to be furnished by the Bidder viii) Declaration for knowledge about entire site conditions in Bidder's letter head and (ix) Declaration against Technical Specification in Bidder's letter head.
2.	Cover-II	Qualification Criteria.
3.	Cover-III	Notice Inviting e-Tender (NIT)
		Instruction to Bidder (ITB)
		General Conditions of Contract (GCC)
		Special Conditions of Contract (SCC)
		<u>FORMATS :</u> (a) Performance Bank Guarantee. (b) Bank Guarantee in lieu of Security Deposit (c) Make In India Clause (d) Bank Guarantee in lieu of Earnest Money Deposit (e) Shares a Land Border (f) Input Tax Credit Format (g) Other (s) format
4	Cover-IV	PRICE BID



BRIDGE AND ROOF CO. (I) LTD.
(A GOVERNMENT OF INDIA ENTERPRISE)
CIN NO. : U27310WB1920GOI003601
Santragachi Station Development Work site,
1st Floor, New Station Building, Platform No. 6
Santragachi, PIN- 711 111, West Bengal

NOTICE INVITING e-TENDER (e-NIT)

Online "Single Percentage Rate (above/below/at par)" Bid(s) / Offer(s) are invited in two part bid system for execution of the following work meeting the prescribed Pre-Qualification Criteria given in Tender Document(s).

Name of Work	NIT No.:
EXECUTION OF RCC ROAD ALONG WITH FOOTPATH, DRAINAGE AND MISCELLANEOUS FINISHING WORK ON SUB-CONTRACT BASIS IN CONNECTION WITH "CONSTRUCTION OF NEW ISLAND PLATFORM AND REFURBISHING OF EXISTING PLATFORMS INCLUDING PLATFORM SHADE AT SANTRAGACHI RAILWAY STATION REGARDING STATION DEVELOPMENT WORK FOR SOUTH EASTERN RAILWAY IN WEST BENGAL.	B AND R/51110/TD/SC/RCC ROAD WORK/01 DTD. 13/06/2024

Last Date of submission of Bid: 27/06/2024 upto 16:00 Hours.

Interested Bidder(s) have to download the Tender document through logging on to Company's Website <http://www.bridgeroof.co.in>

Corrigendum/Addendum, if any shall be hosted in Company's Website <http://www.bridgeroof.co.in> only.

BRIDGE AND ROOF CO.(INDIA) LIMITED
Santragachi Station Development Work site,
1st Floor, New Station Building, Platform No. 6
Santragachi, PIN- 711 111, West Bengal

Notice Inviting Tender (NIT) No.:B AND R/51110/TD/SC/RCC ROAD WORK/01 DTD. 13/06/2024

1. Online "Single Percentage Rate (above/below/at par)"bid(s) / Offer(s) are invited from reputed and experienced parties meeting prescribed qualifying criteria for execution of the following works:
2. **Brief Details of Work:**

Sl. No.	Description of Work	Estimated cost put to Tender	Cost of Tender Document (Non Refundable)	Earnest Money Deposit (EMD)	Time of Completion	Tender Inviting Authority (TIA)
(1)	(2)	(3)	(4)	(5)	(6)	(7)
1	EXECUTION OF RCC ROAD ALONG WITH FOOTPATH, DRAINAGE AND MISCELLANEOUS FINISHING WORK ON SUB-CONTRACT BASIS IN CONNECTION WITH "CONSTRUCTION OF NEW ISLAND PLATFORM AND REFURBISHING OF EXISTING PLATFORMS INCLUDING PLATFORM SHADE AT SANTRAGACHI RAILWAY STATION REGARDING STATION DEVELOPMENT WORK FOR SOUTH EASTERN RAILWAY IN WEST BENGAL.	RS. 207.32 Lakhs	Rs. 5,000.00 + 18% GST (i.e. Rs. 900.00) = Rs.5,900.00(Rupees Five Thousand Nine Hundred only)payable in the form of Demand Draft (DD)/ Pay Order / Banker's Cheque drawn from any Nationalized/Scheduled Bank, in favor of BRIDGE AND ROOF Co. (I) LTD., payable at Kolkata to be submitted along with Tender Documents [No A/c Payee Cheque shall be Considered] .	Rs. 4.36 Lakhs (Rupees Four Lakhs Thirty Six Thousand only) shall be submitted by Bidder(s) along with their offer in the form of Demand Draft (D.D.) / Pay Order / Banker's Cheque valid for minimum 90 (Ninety) days / Bank Guarantee (BG) in prescribed format valid for minimum 06 (Six) months pledged in favour of "BRIDGE AND ROOF Co. (India) Ltd" drawn from any Nationalized/Scheduled Bank, in favour of BRIDGE AND ROOF Co. (I) Ltd., payable at Kolkata shall be submitted along with Tender documents. (No A/c Payee Cheque shall be considered). Exemption of Tender Fee & EMD will not be applicable as per PP Policy, 2012, works contract are not covered under PP Policy as per Letter no. 190/Mech/Cores/Various org/Stakeholder/2021-22 dated 18/19-04-2022. The offer of the bidder shall not be considered further if the Cost of Tender Document is not submitted in the form and manner as stated above and their offer is liable to be rejected.	02½(Two and Half) months from the date of issue of LOI.	Sr. Manager BRIDGE AND ROOF Co. (INDIA) LTD. Santragachi station development Works site

BRIDGE AND ROOF CO. (I) LTD.
(A GOVERNMENT OF INDIA ENTERPRISE)
Santragachi Station Development Work site,
1st Floor, New Station Building, Platform No. 6
Santragachi, PIN- 711 111, West Bengal

3.	CRITICAL DATESHEET:		
	Dates and Time For :-	:	Dates and Time
	Bid Document Publishing Date	:	13/06/2024
	Bid Document Download Start Date	:	13/06/2024
	Bid Submission End Date	:	27/06/2024 at 16:00 Hrs.
	Last date of submitting Tender fees/ earnest money and physical documents, specified as Cover I in Tender Document.	:	28/06/2024 up to 16:00 Hrs.
	Date of Opening of Technical Bid	:	28/06/2024 after 17:30 Hrs.
	Date of Opening of Financial Bid	:	Offer of Techno Commercially qualified bidder(s) shall be opened in Camera.

BRIDGE AND ROOF CO. (INDIA) LTD
(A GOVERNMENT OF INDIA ENTERPRISE)
Santragachi Station Development Work site,
1st Floor, New Station Building, Platform No. 6
Santragachi, PIN- 711 111, West Bengal

EXECUTION OF RCC ROAD ALONG WITH FOOTPATH, DRAINAGE AND MISCELLANEOUS FINISHING WORK ON SUB-CONTRACT BASIS IN CONNECTION WITH "CONSTRUCTION OF NEW ISLAND PLATFORM AND REFURBISHING OF EXISTING PLATFORMS INCLUDING PLATFORM SHADE AT SANTRAGACHI RAILWAY STATION REGARDING STATION DEVELOPMENT WORK FOR SOUTH EASTERN RAILWAY IN WEST BENGAL

NOTICE INVITING TENDER (NIT) No.:B AND R/51110/TD/SC/RCC ROAD WORK/01 DTD. 13/06/2024

ANNEXURE - I

QUALIFYING CRITERIA

QUALIFYING CRITERIA

EXECUTION OF RCC ROAD ALONG WITH FOOTPATH, DRAINAGE AND MISCELLANEOUS FINISHING WORK ON SUB-CONTRACT BASIS IN CONNECTION WITH “CONSTRUCTION OF NEW ISLAND PLATFORM AND REFURBISHING OF EXISTING PLATFORMS INCLUDING PLATFORM SHADE AT SANTRAGACHI RAILWAY STATION REGARDING STATION DEVELOPMENT WORK FOR SOUTH EASTERN RAILWAY IN WEST BENGAL

NOTICE INVITING TENDER (NIT) No.:B AND R/51110/TD/SC/RCC ROAD WORK/01 DTD. 13/06/2024

1.00 QUALIFICATION CRITERIA FOR PARTICIPATION IN THE TENDER:

- a. The Bidder should have successfully executed “Similar Works” of the value during the last **7 years** ending last day of month previous to the one in which applications are invited which should be either of the following:

Three (03) similar completed works each costing not less than **₹ 87.00 Lakhs.**

OR,

Two (02) similar completed works each costing not less than **₹ 109.00 Lakhs.**

OR,

One (01) similar completed work costing not less than **₹ 174.00 Lakhs.**

Note: Similar Works shall mean “Project comprising of any types of Civil Work which consists of Earth Work, PCC, RCC, Steel reinforcement, shuttering etc.’ with labour & materials in any sector in 1(one) Contract/Agreement.

Note for Clause a. above

1. If the qualifying work is completed in the Seven year period, even if it has been started earlier, the same will also be considered as meeting the qualifying Criteria.

2. The work “Executed” means the Tenderer should have achieved the criteria specified above even if the total contract is not closed i.e. under execution and provided the works is not terminated by the client.

- b. **Average Annual Financial Turnover** during the last 03 (Three) years ending **31.03.2023** should not be less than **the amount equal to Rs.65.00 Lakhs.** Copy of Audited Balance Sheet(s) alongwith Turnover Certificate duly signed by Chartered Accountant with his / her Seal, Signature and Registration Number for last 03 (Three) financial years ending **31.03.2023** to be submitted. The year in which no Turnover is shown, would also be considered for working out the average. **Turnover should be of the Bidding Company and not for Subsidiary / Associate Company / Group Company etc.**
- c. The Bidder should not have incurred any loss (**Profit after Tax should be Positive**) in **more than two years during the last five years ending 31st March, 2023. Net Worth of the Company / Firm as on 31st March 2023 should be positive.** Net Worth Certificate for F.Y.: 2022-23 should be submitted duly certified by Chartered Accountant with his / her Seal, Signature and Registration Number.
- d. The bidder must have PAN issued by Competent Authority.
- e. The bidder must have GST Registration Certificate issued by Competent Authority.
Note: Bidder should submit the copy of last filed Monthly / Quarterly GSTR-3B return as GST clearance Certificate along with GST Registration Certificate with offer / bid failing which their offer will not be considered for further evaluation.
- f. The bidder must be P. F. & ESIC registered.
[If not registered with the Concerned Department, then the Bidder should give a declaration in their Letter head along with Techno Commercial part of their Offer towards submission of the same within one month of award of Work and before releasing any Payment in their favour].

- g. The bidder should submit the prescribed Certificate of Declaration for Confirming the Knowledge of Site Conditions [Annexure- II(D)] duly stamped and signed by the B and R's Site-in-Charge during site visit.
[Note: Before submission of offer, the Tenderer is deemed to have inspected the site to study the nature and extent of work involved and also to have obtained first hand information regarding site condition.]
- h. The bidder should have submitted Bank Solvency Certificate from their Banker. Date of issue of Certificate should not be more than 03(Three) months old from the last date of bid submission.
- i. Direct or Indirect Joint Venture(s) / Consortium / Special Purpose Vehicle (SPV) / Special Purpose Entity (SPE) are not permitted to participate.

2. DETAILS TO BE FURNISHED BY THE BIDDER:

- a) Name, Address, Details of the Organization.
- b) Notarized Copy of Completion Certificate along with corresponding LOI/WO or any other documents mentioned in above duly certified by Client's substantiating the above nature as well as Executed Value of Work and Completion Date.
- c) Copy of Audited Balance Sheet duly certified by Chartered Accountant along with Turnover Certificate duly signed by C.A with his/her seal, signature & Registration No. for last **03(Three)** Financial Years, i.e. **2020-2021, 2021-2022 and 2022-2023**. Net worth of the firm as on 31.03.2022 shall be positive.
- d) Photocopy of latest Income Tax Deposition acknowledgement.
- e) Photo copy of PAN Card issued by Income Tax Authority.
- f) PF & ESI Registration Certificate.
[If not registered with the Concerned Department, then the Bidder should give a declaration in their Letter head along-with Techno Commercial part of their Offer towards submission of the same within one month of award of Work and before releasing any Payment in their favour].
- g) Photocopy of GST Registration certificate.

[Note: Bidder should submit the copy of latest filed Monthly / Quarterly GSTR-3B return as GST clearance certificate along-with GST Registration certificate with bid document failing which their offer will not be considered for further evaluation.]

Moreover, contractors having registration in other state (except West Bengal) shall raise their Tax Invoice by charging IGST only.

- h) Information on Litigation History, Liquidated damage, Disqualification etc. declaration in Tenderer letterhead Bidder(s) who had a record of Court Case / Litigation History with BANDR /our Client against previous Tender / Contracts shall not be considered for these Tenders.
- i) Constitution and legal status of the firm including Registration details Partnership Deed, Power of Attorney in case of Partnership firm, Affidavit in case of Proprietorship firm, Memorandum and Article of Association in case of Limited Company.
- j) Name(s) of the Owner/Partners/Promoters and Directors of the Firm/Company.
- k) Details of Key Supervisory personnel in their Co's Roll alongwith deployment schedule of key personnel[**Annexure -P**] & [**Annexure -J**].
- l) List of Work in hand & Current Commitment.
- m) "Purchase preference to Make in India" regarding minimum local content is applicable for the "Local Supplier" for the items/services covered in the Tender [**Annexure -M**].
- n) Bidder Should submit 'Input Tax Credit' as per prescribed format [**Annexure -O**].
- o) List of Tools, Plants & Machineries owned by the company alongwith deployment schedule of Machineries[**Annexure -Q**] & [**Annexure -I**].
- p) Any bidder from a country which shares a land border with India will be eligible to bid in any procurement whether of Goods, Services (Including Consultancy Services / Non Consultancy Services) or works (Including Trunk Projects) only if the Bidder is Registered with the Competent Authority (as per OM dated 23.07.2020) issued by Ministry of Finance [**Annexure -N**].
- q) Bidder(s) (Only Private Limited / Limited Company) should submit the Copy of **Screenshot of MCA Portal showing 'Active' Status**. Non-submission of above status, their offer may be rejected for further evaluation.
Responsibility Matrix (Site Infrastructure & Other) [**Annexure - X**].
- r)

3. The company reserves the right to waive minor deviations if they do not materially affect the capability of the Bidder to perform the contract.
4. Bidder is liable to disqualified, even though they meet the qualifying criteria, if they.
 - a) Made misleading or false representations, statements and attachments submitted in proof of the qualification requirements, and/or.
 - b) Record of poor performance such as abandoning the works, not properly completing the supply order, inordinate delays in completion or supply, litigation history with B AND R or ISBT, or financial failures etc.
 - c) If the Bidder deliberately gives wrong information/submit fake, false, fabricated, forged documents in his tender, B AND R reserves the right to reject such tender at any stage or to cancel the contract if awarded and forfeit the Earnest Money Deposit/ Retention Money / any other money due and also will be kept under Black Listing /Holiday List from being eligible for bidding in any contract with BRIDGE AND ROOF Co.(I) Ltd (B AND R) for the period of 2 years from the date of occurrence.
 - d) If bidder or any of constituent partner had been debarred to participate in tender by any Govt. Department/ Govt. Undertaking /Semi Govt. Department/ Local bodies during the last 5 (five) years prior to the date of this NIT such debarment will be considered as disqualification towards eligibility. A declaration in this respect has to be furnished by the bidders as per prescribed format (**Annexure: K and R**), without which the Technical Bid shall be treated as non-responsive.

Technical Bid shall be treated as non-responsive if anything adverse has come to the notice of the Tender Inviting Authority against the Firm/Agency/bidder so far as his performance within the jurisdiction of this Company.

Bidders shall, on request, provide any necessary authority and assistance to enable relevant enquiries to be carried out.

After submission of their Offer, Bidder must notify B AND R promptly, if there is any:

- i) Substantial change in their financial or technical capacity.
- ii) Change in their business (such as Company name, address)
- iii) Change of ownership or holding, including any transfer of key personnel.
- iv) Any other significant change in information provided in the Offer.

The Bidder must provide any further details required for the review upon request from B AND R. Failure to comply with any request by B AND R for such information will result in rejection of their offer.

B AND R may, in its absolute discretion suspend or disqualify a Bidder/Bidders who, at any time, is considered to have breached any of the qualification conditions or has performed in an unsatisfactory manner without assigning any reason whatsoever.

B AND R will not be liable for any loss or damages incurred by the Bidder/ Bidders in the above exercise.

5. **Disqualification of Bid:** B AND R reserves the right to disqualify such bidders who had a record of not meeting the contractual obligations against earlier contracts entered into with the B AND R.
6. Due date of submission shall be written on all the covers / envelopes of the application / bid without fail.
7. Application / Bids received after the due date and time shall not be accepted. No request for extension of the due date indicated shall be entertained.
8. Telegraphic or Fax or Email offers shall not be accepted under any circumstances.

9. B AND R may, in its absolute discretion suspend or disqualify a Bidder / Bidders who, at any time, is considered to have breached any of the qualification conditions or has performed in an unsatisfactory manner without assigning any reason whatsoever.

[BIKASH SARKAR]
Sr. Manager
BRIDGE AND ROOF CO. (I) LTD.

For and on behalf of Tenderer

Signed and Stamped of Tenderer

BRIDGE AND ROOF CO. (INDIA) LTD
(A GOVERNMENT OF INDIA ENTERPRISE)
Santragachi Station Development Work site,
1st Floor, New Station Building, Platform No. 6
Santragachi, PIN- 711 111, West Bengal

EXECUTION OF RCC ROAD ALONG WITH FOOTPATH, DRAINAGE AND MISCELLANEOUS FINISHING WORK ON SUB-CONTRACT BASIS IN CONNECTION WITH "CONSTRUCTION OF NEW ISLAND PLATFORM AND REFURBISHING OF EXISTING PLATFORMS INCLUDING PLATFORM SHADE AT SANTRAGACHI RAILWAY STATION REGARDING STATION DEVELOPMENT WORK FOR SOUTH EASTERN RAILWAY IN WEST BENGAL

NOTICE INVITING TENDER (NIT) No.:B AND R/51110/TD/SC/RCC ROAD WORK/01 DTD. 13/06/2024

ANNEXURE - II

INSTRUCTION TO BIDDERS

BRIDGE AND ROOF CO. (INDIA) LIMITED

INSTRUCTIONS TO BIDDERS:

- 1.00 a. Bids are invited by B AND R in two stage four cover system from resourceful & capable tenderers fulfilling the qualifying criteria furnished in Annexure –I of the NIT by Bridge And Roof Co. (I) Ltd. (B AND R) for “Execution of RCC Road along with Footpath, Drainage and miscellaneous Finishing work on Sub-Contract Basis in connection with “Construction of New Island Platform and Refurbishing of Existing platforms including platform shade at Santragachi Railway Station regarding Station Development work for South Eastern Railway in West Bengal” to be submitted at Bridge And Roof Co. (India) Limited, Santragachi Station Development Project site, Santragachi, Howrah on or before prescribed date and time of NIT.
- 1.00b. Purpose:
It is the purpose of these instructions to serve as a guide to Bidders for preparing offer for “Execution of RCC Road along with Footpath, Drainage and miscellaneous Finishing work on Sub-Contract Basis in connection with “Construction of New Island Platform and Refurbishing of Existing platforms including platform shade at Santragachi Railway Station regarding Station Development work for South Eastern Railway in West Bengal.”
- 1.00c. The Tenderer, at their own responsibility and risk is encouraged to visit and examine the site of works and its surroundings and obtain all information that may be necessary for preparing the Bid and entering into a Contract for the work as mentioned in the Notice Inviting e-Tender, the cost of visiting the site shall be at the Bidder's own expense.
- 1.00 d. CONDITIONAL / INCOMPLETE TENDER will not be accepted under any circumstances.
- 2.00 The Chairman cum Managing Director / Director (Project Management) of B AND R shall be the Accepting Officer here-in-after referred to as such for the purpose of this Contract.
- 3.00 The Tenderer shall quote in **figures as well as in words** rate(s) tendered. In case of any discrepancy between the two, rate(s) quoted in words shall prevail **rounded upto two decimals**.
- 4.00 Submission of a Tender by a tenderer implies that he has read this notice and all other Tender Documents and has made himself aware of the scope and the specifications, Drawings of the work to be done and of conditions of contract and local conditions and other factors having bearings on the execution of the work.
- 5.00 Procedure for submission of Bid:
- i. **Tender Fee :**
Rs. 5000.00 + 18% GST =Rs. 5900.00 i.e. (Rupees Five Thousand Nine Hundred only) payable by Demand Draft (D.D.) / Pay Order / Banker's Cheque drawn from any Scheduled /Nationalized Bank, in favour of Bridge And Roof Co. (I) Ltd., payable at Kolkata shall be submitted along with Tender documents. (No A/c Payee Cheque shall be considered.)
The offer of the bidder shall not be considered further if the Cost of Tender Document is not submitted in the form and manner as stated above and their offer is liable to be rejected.
- ii. **Earnest Money Deposit (EMD) :**
Rs. 4.36 Lakhs (Rupees Four Lakhs Thirty Six Thousand only) shall be submitted by Bidder(s) alongwith their offer in the form of Demand Draft (D.D.) / Pay Order / Banker's Cheque valid for minimum 90 (Ninety) days / Bank Guarantee (BG) in prescribed format valid for minimum 06 (Six) months pledged in favour of “BRIDGE AND ROOF Co. (India) Ltd” drawn from any Nationalized/Scheduled Bank, payable at Kolkata shall be submitted alongwith Tender documents. **(No A/c Payee Cheque shall be considered).**
Exemption of **Tender Fee & EMD** will not be applicable as per PP Policy, 2012, works contract are not covered under PP Policy as per Letter no. 190/Mech/Cores/Various org/Stakeholder/2021-22 dated 18/19-04-2022. The offer of the bidder shall not be considered further if the Cost of Tender Document is not submitted in the form and manner as stated above and their offer is liable to be rejected.

The offer of the bidder shall not be considered further if the Earnest Money Deposit (EMD) is not submitted in the form and manner as stated above and their offer is liable to be rejected.

EMD amount in the form of BG submitted by Successful Bidder(s) shall be retained till submission of valid BG towards Performance Guarantee and the same shall be released thereafter. EMD amount in the form of Demand Draft (D.D.) / Pay Order / Banker's Cheque submitted by Successful Bidder(s) will be treated as a part of Security Deposit / Retention Money and the deduction towards the Security Deposit / Retention Money will be started after adjustment of EMD amount against value of work done in R/A bills. EMD amount of Un-Successful Bidder(s) shall be returned to them at the earliest after expiry of the final bid validity and latest on or before the 30th day after the award of the Contract. However, EMD amount of Un-Successful Bidder(s) during First Stage i.e. Technical Evaluation etc. should be returned within 30 days of declaration of result of First Stage i.e. Technical Evaluation. No interest will be payable on Earnest Money Deposit.

- ii) The successful Tenderer shall accept the LOI within 3(Three) days from receipt of the same, failing which the award of work may be liable to be cancelled.
- iii) If any tenderer withdraws or make any changes in his offer already submitted before the expiry of the above validity period or any extension thereof without the written consent of the company, their offer is liable to be rejected.
- iv) B AND R reserves the right to cancel the job in case of the successful tenderer-
 - a) After opening of Tender, revokes his tender within the validity period or increases his earlier quoted rates.
 - b) Does not commence the work within the period as per LOI/Contract. In case the LOI/Contract is silent in this regard then within 07 days after award of LOI/contract. If the contractor, without reasonable cause or valid reasons, commits default in commencing the execution of the work within aforesaid time limit, B AND R shall without prejudice to any other right or remedy, be at liberty, to give 10 days' notice in writing to the contractor to commence the work and to revoke /rescind the letter to intent.

6.00 Bid shall be submitted in 2(two)parts:

- a) **Part-I** : Containing one Copy each of following documents:
Bidder should submit the **Tender Fee and EMD, Letter of Submission (in Bidder's letter head), No Deviation Certificate (in Bidder's Letter Head), Declaration for knowledge about entire site conditions(in Bidder's Letter Head), Detail of information to be furnished by the bidder and Power of Attorney in favour of the person who has signed the bid, as prescribed** in Technical Cover as specified in the Tender. The original should be posted / couriered / given in person to the Tender Inviting Authority, within specified date and time for the Tender.

Documents pertaining to qualifying criteria furnished in Annexure – I of the NIT.

Signed and Stamped NIT, ITT, GCC, SCC, Un-priced SOQR with the word "Quoted", Drawing i.e. complete NIT documents.

Part- II:

Containing Original priced offer in the prescribed format of the tender document duly signed and stamped.

Tenderers should quote as "**above / below / at par**" as per the Price Bid format in the allotted space only.

Part – I & Part – II shall be submitted in separate sealed envelope and to be put in one outer cover and cloth bound and sealed. Both inner & outer covers shall be super scribed as follows: -

Part - I

Techno-Commercial bid for "**Execution of RCC Road along with Footpath, Drainage and miscellaneous Finishing work on Sub-Contract Basis in connection with "Construction of New Island Platform and Refurbishing of Existing platforms including platform shade at Santragachi Railway Station regarding Station Development work for South Eastern Railway in West Bengal.**

Part -II

Priced Offer for "Execution of RCC Road along with Footpath, Drainage and miscellaneous Finishing work on Sub-Contract Basis in connection with "Construction of New Island Platform and Refurbishing of Existing platforms including platform shade at Santragachi Railway Station regarding Station Development work for South Eastern Railway in West Bengal.

Outer most cover:

Shall be super scribed with Offer for "Execution of RCC Road along with Footpath, Drainage and miscellaneous Finishing work on Sub-Contract Basis in connection with "Construction of New Island Platform and Refurbishing of Existing platforms including platform shade at Santragachi Railway Station regarding Station Development work for South Eastern Railway in West Bengal

Due date for submission of Bid(s) is 27/06/2024 upto 16:00 Hrs. and shall be addressed to:

Senior Manager,

Bridge And Roof Co. (India) Ltd.,

Santragachi Station Development Work site,

1st Floor, New Station Building, Platform No. 6

Santragachi, PIN- 711 111, West Bengal

- 6.1 Hard copy of offer (Techno commercial and Price) shall be opened in camera.
- 6.2 Bids received after the due date and time shall not be accepted.
- 6.3 Telegraphic or Fax or Email offers shall not be accepted under any circumstances.
- 6.4 The right to reject any or all offer(s) or split up the total requirement and award the contract to one or to more than one Bidder if considered necessary or to cancel the Tender rests with B&R.
- 6.5 Price Bids of those Bidders who will be Techno- commercially qualified for the subject job on the basis of evaluation of techno commercial bids, will be opened on specified date. The date & time to open the price bid (Part-II) shall be intimated to the bidders and in such a case, one representative of the bidder shall be allowed to attend. B&R's decision in this regard is final & binding.
- 6.6 The successful Tenderer shall accept the LOI within 3(Three) days from receipt of the same, failing which the award of work may be liable to be cancelled.
- 6.7 If any tenderer withdraws or make any changes in his offer already submitted before the expiry of the above validity period or any extension thereof without the written consent of the company, their offer is liable to be rejected.
- 6.8 B AND R reserves the right to cancel the job in case of the successful tenderer –
 - i) After opening of Tender, revokes his tender within the validity period or increases his earlier quoted rates.
 - ii) Does not commence the work within the period as per LOI/Contract. In case the LOI/Contract is silent in this regard then within 07 days after award of LOI/contract. If the contractor, without reasonable cause or valid reasons, commits default in commencing the execution of the work within aforesaid time limit, B AND R shall without prejudice to any other right or remedy, be at liberty, to give 10 days' notice in writing to the contractor to commence the work and to revoke /rescind the letter to intent.
- 7.00 Tender submitted by Tenderer shall remain valid for acceptance for a period of **90 (Ninety) days** from the date set for opening of the tender. The Tenderer shall not be entitled within the said period of **90 (Ninety) days** to revoke or cancel or vary the tender given or any item thereof, without the consent of B AND R. In case Tenderer revokes or cancels or varies his tender in any manner without the consent of B AND R, within this period, his earnest money will be forfeited.
- 8.00 B AND R does not bind them to accept the lowest or any tender and B AND R shall not assign any reason for non-acceptance and/or rejection of any and/or all tenders if such a case arises. B AND R is also at liberty to award the work or part of work to any Tenderer.
- 9.00 Bidder has to quote **(above/below/at par)** as per BOQ Sheet provided in Tender. Quote Sheet and Bill of Quantities (BOQ)/ Schedule of Quantities and Rates (SOQR) shall be submitted alongwith your offer.
- 10.00 Bidder should submit Hard copy of the following documents along with their Techno-commercial bid:-
 - a) **Tender Fee: Rs. 5,000.00 + 18% GST (i.e. Rs. 900.00) = Rs. 5,900.00(Rupees Five Thousand Nine Hundred only)** payable by Demand Draft (D.D.) / Pay Order / Banker's Cheque drawn from any Nationalized/Scheduled Bank, in favour of Bridge andRoof Co. (I) Ltd., payable at Kolkata shall be submitted along with Tender documents (Non- refundable) (in original)**[No A/c Payee Cheque shall be Considered]** and

Earnest Money Deposit (EMD) : Rs. 4.36 Lakhs (Rupees Four Lakhs Thirty Six Thousand only)in- the form of Demand Draft (D.D.) / Pay Order / Banker's Cheque valid for minimum 90 (Ninety) days / Bank Guarantee (BG) in prescribed format valid for minimum 06 (Six) months in favour of "BRIDGE AND ROOF Co. (India) Ltd" along with Offer. **[No A/c Payee Cheque shall be Considered]**

- b) **MSMEs / NSIC / SSI registered parties:** Copy of the Valid Registration Certificate mentioning SC/ST/General / Women Entrepreneurs.
- c) Power of Attorney in favour of the person who has signed the bid.
- d) Letter of Submission (in Bidder's letter head) as per prescribed format **[Annexure- II(A)]**.
- e) Detail of information to be furnished by the bidder **[Annexure- II(B)]**.
- f) No Deviation Certificate in Bidder's Letter Head as per prescribed format **[Annexure- II(C)]**.
- g) Certificate of Declaration for Confirming the Knowledge of Site Conditions. **[Annexure- II(D)]**.
- i) Declaration Against Technical Specification **[Annexure- II(E)]**.
- j) Details of Present Commitments and work executed by the Tenderer **[Annexure –H]**.
- k) Deployment Schedule of Construction Equipment **[Annexure –I]**.
- l) Deployment Schedule of supervisory personnel **[Annexure –J]**.
- m) Affidavit in Non – Judicial Stamp Paper certified by Notary Public or 1ST Class Magistrate **[Annexure- (K)]**.
- n) Purchase Preference to Make in India **[Annexure –M]**.
- o) Compliance Certificate Regarding Bidders from Countries which shares a Land Border with India in Bidder's Letter Head **[Annexure-N]**.
- p) Information regarding current litigation, debarring expelling of bidder or abandonment of work by the bidder **[Annexure- R]**.
- q) Compliance to bid requirement as per **[Annexure – S]**.
- r) Declaration by the Bidder as per **[Annexure – T]**.
- s) Preamble to schedule of Quantities and Rates as per **[Annexure – R1]**.
- t) Documents pertaining to Qualifying Criteria as per Annexure –I.

Unless otherwise specified, Techno-Commercial Bids will be opened on the next working day after last due date of submission of offer at 17:30 hrs.

Price Bids of those Bidders who will be Techno- commercially qualified for the subject job on the basis of evaluation of Techno Commercial Bids will be opened only and B AND R's decisions in this regard shall be final and binding upon the Tenderer.

- 11.00 The Employer reserves the right to postpone the date for opening of Tenders and will give timely notice of any such postponement to the prospective Tenderers.
- i) Acceptance or rejection of any tender is left entirely to the discretions of the authority empowered to deal with the matter and no query/ explanation can be demanded by any Tenderer for the cause of rejection of his tender.

- ii) B AND R may, in its absolute discretion suspend or disqualify a Bidder / Bidders who, at any time, is considered to have breached any of the qualification conditions or has performed in an unsatisfactory manner without assigning any reason whatsoever.
 - iii) If the Tenderer deliberately gives wrong information in his Tender or creates circumstances for the acceptance of his tender, the Employer reserves the right to reject such Tender at any stage.
 - iv) If a Tenderer seeks in clarifying his quotations or rates, this should only be done in a separate covering letter. No material modifications to the specifications, item descriptions, Contract clause, etc. will however be entertained. Other clarifications may be considered. The contents of a covering letter sent along with the tender will be considered as part of the quotation. If any of these conditions admitted for consideration has a financial bearing on the cost quoted, the additional cost arising out of these conditions will be added for comparative evaluation of tenders.
- 12.00 By submitting a tender for the work, a Tenderer will be deemed to have satisfied himself by actual inspection of the site and locality of the work, that the rates quoted by him in the tender will be adequate to complete such work according to the specifications and conditions attached thereto and he has taken into account all conditions and difficulties that may be encountered during its progress and to have quoted labour and material rates which shall include cost of materials with taxes, Octroi and other duties, lead, lift, loading and unloading, freight for materials, labour cess and all other charges including the furnishing of all plant, Equipment, tools, scaffolding and other facilities and services, necessary or proper for the completion and maintenance of the work, except such as may be otherwise expressly provided for in the Contract documents for the completion and maintenance of the work to the entire satisfaction of the Engineer in Charge.
- 13.00 The successful Tenderer(s) shall make his own arrangements for all materials, except as specified in the Contract, if any.
- 14.00 The quantities shown in the attached schedule are given as a guide and approximate only and are subject to variation according to the needs of the Employer. The Employer accepts no liability for their accuracy. The Employer does not guarantee work under each item of the schedule.
- 15.00 Each Tender shall be digitally signed by the Tenderer with his Digital signature. Tender by partnership or joint family firm may be signed in the firm's name by one of the partners or the karta or manager as the case may be or any other duly authorized representative followed by the name and designation of the persons so signing. An attested copy of the partnership deed must accompany the tender of any partnership firm. Tenders by a company shall be signed with the name of the company by a person authorized on his behalf and Power of Attorney or other satisfactory proof showing that the person signing the tender documents on behalf of the company is duly authorized to do so, shall accompany the tender. The Employer will not be bound by any Power of Attorney granted by the Tenderers or by changes in the composition of the firm, made subsequent to the execution of the Contract. It may, however, recognize such Power of Attorney and changes after obtaining proper legal advice, the cost of which may be chargeable to the Sub-contractor.
- 16.00 With their quotations the Tenderers shall submit by digitally signing all schedules, specifications, special conditions, etc. in token of acceptance thereof. The signature on the tender schedule alone shall also be deemed to be taken as acceptance of all these.
- 17.00 If a Tenderer expires after the submission of his tender or after the acceptance of his tender the Employer may deem such tender as cancelled. If a partner of the firm expires after the submission of their tender, the Employer may deem such tender as cancelled UNLESS THE FIRM RETAINS its character.
- 18.00 If the Tenderer has a relative employed in any capacity in the BRIDGE AND ROOF Company (India) Limited, he shall inform the authority calling for tenders of the said fact when submitting his tender, failing which his Contract may be rescinded. If the said fact subsequently comes to light he shall be liable to make good to the Employer any loss or damage resulting from such cancellation.
- 19.00 No Contract work however petty may be carried out except under and in accordance with a duly executed agreement or on a special written authority from a duly authorized officer of the Employer.
- 20.00 No Agreement is valid unless signed by Contractor or his duly authorized Agent and by a competent a person on behalf of the Employer.

- 21.00 The form of Agreement, Form of Tender, Invitation to Tender, Instruction to Tenderer, Special Conditions of Contract, Specifications, Drawing, Time Schedule and the rates and amount accepted against the items of the Tender schedule together with the tender covering letter, and all correspondence entered into between the Employer and the Tenderer prior to the issue of the Letter of Intent awarding the work, and the Letter of Intent shall form the Contract.
- 22.00 If there is any conflict between any of the provisions in the special conditions and those in any of the other documents referred to, the provisions in the special conditions shall prevail.
- 23.00 If there be any difference between the description in the specification and drawings and the works items in the tender schedule, the work items in the Tender schedule shall prevail for determining the rates.
- 24.00 Acceptance of the tender will be intimated to the successful Tenderer through a Letter of Intent.
- 25.00 On completion of the work, Contractor will hand over the work to the Employer /B AND R in approved format and after clearing the site to the entire satisfaction of the Owner.
- 26.00 Before issuance of the Work Order, the Tender Inviting Authority may verify the credential and other Documents of the lowest Tenderer if found necessary. After verification, if it is found that such documents submitted by the lowest Tenderer is either manufactured or false, in that case the Tender will be cancelled and in addition the Tenderer will be put into holiday list and debarred from participation in the Re- Tender.
- 27.00 Penalty for suppression / distortion of facts: If any Tenderer fails to produce the original hard copies of any documents on demand of the Tender Inviting Authority within a specified time frame or if any deviation is detected in the hard copies from the uploaded soft copies or if there is any suppression of documents, the Tenderer will be suspended from participating in the tenders on e-Tender platform for 2(two) years. In addition, his user ID will be deactivated. Besides, B AND R may take appropriate legal action against such defaulting Tenderer.
- 28.00 Successful Bidder shall have to execute the work in such a manner so that the appropriate service level of work / job is kept during progress of work and a period of 5(Five) year from the date of successful Completion of the work to the entire satisfaction of Engineer-In-Charge. If any defect / damage is found during the Period as mentioned above, the Agency shall make the same good at his own expenses up to the specification at par with instant project work.
- 29.00 Possession of valid Digital Signature Certificate (DSC) and enrollment/registration of the Sub-contractors/ bidders on the e- procurement/e-tender portal is a prerequisite for e-tendering.
- 30.00 Sub-contractor/Bidder may go through the tenders published on the site and download the required tender documents/schedules for the tenders he/she is interested.
- 31.00 After downloading / getting the tender document/schedules, the Bidder should go through them carefully and then submit the documents as asked, otherwise bid will be rejected.
- 32.00 If there are any clarifications, this may be obtained through the Tender site, or through "the contact details". Bidder should take into account the corrigendum published before submitting the bids online.
- 33.00 From 'my tender' folder, he/she selects the tender to view all the details indicated.
- Bidder selects the tender which he/she is interested in by using the search option and then moves it to the "my tenders" folder.
- 34.00 It is construed that the bidder has read all the terms and conditions before submitting their offer. Bidder should go through the tender schedules carefully and upload the documents as asked; otherwise, the bid will be rejected.

Letter of Submission

(To be submitted by the Bidder in their Letter Head)

- A. Single Percentage Rate Tender for “Execution of RCC Road along with Footpath, Drainage and miscellaneous Finishing work on Sub-Contract Basis in connection with “Construction of New Island Platform and Refurbishing of Existing platforms including platform shade at Santragachi Railway Station regarding Station Development work for South Eastern Railway in West Bengal.”

TENDER

I/We have read and examined the Instructions to Bidders, General Conditions of Contract (GCC), Special Condition of Contract (SCC), Technical Specification, Schedule of Quantities and other documents and Rules referred to in the conditions of contract and all other contents in the tender document for the work.

I/We hereby tender for the execution of the work specified for the “Execution of RCC Road along with Footpath, Drainage and miscellaneous Finishing work on Sub-Contract Basis in connection with “Construction of New Island Platform and Refurbishing of Existing platforms including platform shade at Santragachi Railway Station regarding Station Development work for South Eastern Railway in West Bengal” within the time specified in Tender and in accordance in all respects with the specifications and the Conditions of contract (GCC and SCC) and with such materials as are provided for, by and in respects in accordance with, such conditions so far as applicable.

We agree to keep the tender open for **90 (Ninety) days** from the due date of submission of tender thereof and not to make any modifications in its terms and conditions.

The cost of Tender Document of value **Rs. 5,000.00 + 18% GST (i.e. Rs. 900.00) = Rs. 5,900.00 (Rupees Five Thousand Nine Hundred only)** has been deposited in the form of A/c Payee Demand Draft (DDs) / Pay Order/ Banker's Cheque of a scheduled bank issued in favour of BRIDGE AND ROOF Co. (I) Ltd.

We have also submitted

Earnest Money Deposit (EMD): Rs. 4.36 Lakhs (Rupees Four Lakhs Thirty Six Thousand only) in the form of Demand Draft (D.D.) / Pay Order / Banker's Cheque valid for minimum 90 (Ninety) days / Bank Guarantee (BG) in prescribed format valid for minimum 06 (Six) months in favour of “BRIDGE AND ROOF Co. (India) Ltd”.

We accept that we will automatically be kept under Black Listing /Holiday List from being eligible for bidding in any contract with BRIDGE AND ROOF Co.(I) Ltd (B AND R) for the period of 2 (Two) years from the date of occurrence and BRIDGE AND ROOF Co. (I) Ltd and his successors in office shall without prejudice to any other right or remedy, be at liberty to forfeit the said Earnest Money and PBG(if submitted), if we are in breach of our obligation(s) under the bid conditions, because we:

- (a) have withdrawn our Bid during the period of bid validity specified in the Letter of Bid; or
- (b) having been notified of the acceptance of our Bid by B AND R during the period of bid validity, (i) fail or refuse to execute the Contract, if required, or
- (ii) have failed or refused to furnish the Performance Guarantee within prescribed period, in accordance with the Clause of the Tender.

We understand this EMD shall expire if we are not the successful Bidder, upon finalization of Tender or the validity of Bid whichever is earlier. Further, if I/we fail to commence work as specified, I/we agree that BRIDGE AND ROOF Co. (I) Ltd or his successors in office shall without prejudice to any other right or remedy available in law, be at liberty to forfeit the performance guarantee absolutely,

I/we hereby declare that I/we shall treat the tender documents, Technical Specification and other records connected with the work as secret / confidential documents and shall not communicate information derived there from to any person other than a person to whom I/we am/are authorized to communicate the same or use the information in any manner prejudicial to the safety of the State.

Date : _____ Signature of Contractor and Postal Address

Witness: _____

Address: _____

Occupation: _____

BRIDGE AND ROOF CO. (INDIA) LTD.
DETAILS OF INFORMATION TO BE FURNISHED BY THE BIDDER

Bidders are requested to furnish the following information along with their offer in their Letter head :-

A. Name of the Bidder:

- i) Postal Address
- ii) Telephone / Mobile Number
- iii) Telefax Number
- iv) e-mail
 Address: (Compulsory as all future communications shall be done through e-mails)

- v) Contract Person

B) Contact person at Kolkata

- i) Postal Address
- ii) Telephone / Mobile Number
- iii) Tele fax Number
- iv) e-mail Address
- v) Contract Person

C) Business Details

- i) Permanent Account number:
- ii) GST Number
- iii) SSI / NSIC / MSME Registered Party
 - a) Registration No. and Dated
 - b) Registration under Works / Manufacturer
 - c) Validity
 - d) Category
 - e) Owner under Category (General / SC/ ST / Women)

D) Name of Bank Signatory

(Signature of the Tenderer's with Stamp)

BRIDGE AND ROOF CO. (INDIA) LIMITED

[TO BE SUBMITTED IN BIDDER'S LETTER HEAD]

NO DEVIATION CERTIFICATE

To,
Senior Manager,
Bridge And Roof Co. (India) Ltd.,
Santragachi Station Development Work site,
1st Floor, New Station Building, Platform No. 6
Santragachi, PIN- 711 111, West Bengal

Subject: No Deviation Certificate for "Execution of RCC Road along with Footpath, Drainage and miscellaneous Finishing work on Sub-Contract Basis in connection with "Construction of New Island Platform and Refurbishing of Existing platforms including platform shade at Santragachi Railway Station regarding Station Development work for South Eastern Railway in West Bengal."

NOTICE INVITING TENDER (NIT) No.:B AND R/51110/TD/SC/RCC ROAD WORK/01 DTD. 13/06/2024

Dear Sir,

With reference to above this is to confirm that as per Tender conditions we have visited Site before submission of our Offer and noted the job content and site condition etc. We also confirm that we have not changed/modified the above tender documents and in case of observance of the same at any stage it shall be treated as null and void.

We hereby also confirm that we have not taken any deviation from Tender Clause together with other reference as enumerated in the above referred Tender and we hereby convey our unqualified acceptance to all terms and conditions as stipulated in the Tender Document.

In the event of observance of any deviation in any part of our offer at a later date whether implicit or explicit the deviations shall stand null and void.

We confirm to have submitted/uploaded offer/documents in accordance with tender instructions with acceptance of the terms and conditions of the tender by us and as per aforesaid references

Thanking you,

Yours faithfully,

(Signature, date and Seal of Authorized
representative of the Tenderer)

BRIDGE AND ROOF CO. (INDIA) LIMITED

CERTIFICATE OF DECLARATION
FOR CONFIRMING THE KNOWLEDGE OF SITE CONDITIONS

(To be submitted in the bidder's letter head)

We, _____ (Name of the Sub-Contractor and their Full Address) _____
_____ hereby declare and confirm that we have visited the project site
under the subject namely, "Execution of RCC Road along with Footpath, Drainage and miscellaneous Finishing work
on Sub-Contract Basis in connection with "Construction of New Island Platform and Refurbishing of Existing
platforms including platform shade at Santragachi Railway Station regarding Station Development work for South
Eastern Railway in West Bengal." and acquired full knowledge and information about the site conditions, wage structure,
Industrial climate and total work involved. We further confirm that the above information is true and correct and we will not
raise any claim of any nature due to lack of knowledge of site condition.

Tenderer's Name and Address

(Signature of the Tenderer with Stamp)

Place :

Date :

Site visit conducted on: _____

Signature of Site-in-Charge

BRIDGEAND ROOF CO. (INDIA) LIMITED
(A GOVT. OF INDIA ENTIERPRISE)

NOTICE INVITING TENDER (NIT) No.:B AND R/51110/TD/SC/RCC ROAD WORK/01 DTD. 13/06/2024

DECLARATION AGAINST TECHNICAL SPEICFCATION

(To be submitted in the bidder's letter head)

We, _____ (Name of the Sub-Contractor and their Full Address) _____

_____ hereby declare and confirm that we have gone through all the technical specifications and drawings attached with this NIT under the subject work "Execution of RCC Road along with Footpath, Drainage and miscellaneous Finishing work on Sub-Contract Basis in connection with "Construction of New Island Platform and Refurbishing of Existing platforms including platform shade at Santragachi Railway Station regarding Station Development work for South Eastern Railway in West Bengal." and acquired full knowledge and total work involvement based on which we have submitted the price bid.

Tenderer's Name &Address.

(Signature of the Tenderer with Stamp)

Place:

Date:

[A] DETAILS OF WORK IN HAND

Last day of Month Previous to the one in which bids are invited

Name of work: " Execution of RCC Road along with Footpath, Drainage and miscellaneous Finishing work on Sub-Contract Basis in connection with "Construction of New Island Platform and Refurbishing of Existing platforms including platform shade at Santragachi Railway Station regarding Station Development work for South Eastern Railway in West Bengal

NOTICE INVITING TENDER (NIT) No.: B AND R/51110/TD/SC/RCC ROAD WORK/01 DTD. 13/06/2024

I/We _____, age _____ years, son of _____ do hereby solemnly affirm and declare as follows for and on behalf of Firm _____

Sl. No.	Full postal Address of client and Name of Officer-in-Charge with telefax / Telephone No	Description of work	Value of contract	Date of commencement of work	Scheduled Completion period	Completion % as on date	Expected date of completion	Amount of Balance work during the period of Next 12 Months from the date of declaration	Remarks
1	2	3	4	5	6	7	8	9	10

[B] LIST OF WORKS EXECUTED

Name of Employer	Name of location and name of work	Contract price in Indian Rupees/ Agreement no.	Major Items of works	Date of starting the work as per Agreement	Stipulated date of completion of the work as per Agreement	Actual date of completion of the work	Reasons for delay in starting/ completion, if any
1	2	3	4	5	6	7	8

It is certified that the above particulars furnished are true and correct. If any information given is found to be misleading at a later date, WO/ B AND R will have the authority to take necessary action as per provision of the contract and as per laid down procedure of the Company

Note: The above information is to be certified by the Engineer in Charge / Employer not below the rank of Executive Engineer.

Signature of the Bidder

Date

DEPLOYMENT SCHEDULE OF CONSTRUCTION EQUIPMENT

Name of Work:“ Execution of RCC Road along with Footpath, Drainage and miscellaneous Finishing work on Sub-Contract Basis in connection with “Construction of New Island Platform and Refurbishing of Existing platforms including platform shade at Santragachi Railway Station regarding Station Development work for South Eastern Railway in West Bengal”.

NOTICE INVITING TENDER (NIT) No.:B AND R/51110/TD/SC/RCC ROAD WORK/01 DTD. 13/06/2024

Sl. No.	Description	Minimum Required	1 st Month	2 nd Month	3 rd Month	Total (3 Months)
1.	Concrete Mixer Machine	1 No.				
2.	Excavator cum Backhoe Loader	1 No.				
3.	Tractor with Trolley	1 No.				
4.	Vibrator	1 No.				
5.	Jack Hammer / Concrete breaker	1 No.				
6.	DG Set	1 No.				

Bidder understands that the said proposal represents the minimum deployment and the Bidder acknowledges that the said deployment may have to be augmented with additional number and/or categories, if required, If directed by Engineer-in-Charge, in order to complete the work within the completion schedule, to align with the project overall schedule and within quoted price. Bidders should add the other categories of applicable equipment in above list.

Signature of the bidder _____

Name of Bidder _____

Company Seal _____

DEPLOYMENT SCHEDULE OF SUPERVISORY PERSONNEL

Name of Work: " Execution of RCC Road along with Footpath, Drainage and miscellaneous Finishing work on Sub-Contract Basis in connection with "Construction of New Island Platform and Refurbishing of Existing platforms including platform shade at Santragachi Railway Station regarding Station Development work for South Eastern Railway in West Bengal."

NOTICE INVITING TENDER (NIT) No.:B AND R/51110/TD/SC/RCC ROAD WORK/01 DTD. 13/06/2024

Sl. No.	Supervisory Personnel	Minimum Nos. and Experience	Qualification	1 st Month	2 nd Month	3 rd Month	Total (3 Months)
1.	Site Engineer	1 No. (5 years)	Degree/ Diploma in Civil Engineering				
2.	Site Supervisor	1 No. (6 years)	H.S. or equivalent in any grade				

Bidder understands that the said proposal represents the minimum deployment and the Bidder acknowledges that the said deployment may have to be augmented with additional number and/or categories, if required, if directed by Engineer-in-Charge, in order to complete the work within the completion schedule, to align with the project overall schedule and within quoted price. Bidders should add the other categories of applicable it personnel in above list.

Signature of the bidder _____

Name of Bidder _____

Company Seal _____

Affidavit in Non – Judicial Stamp Paper certified by Notary Public or 1ST Class Magistrate

- 1) The undersigned also hereby certifies that neither our firm M/s. _____ nor any of constituent partner had been debarred to participate in tender by any Government Department during last 7 (Seven) years prior to the date of this N.I.T.
- 2) The undersigned would authorize and request any Band, person, Firm or Corporation to furnish pertinent information as deemed necessary and / or as requested by BRIDGE AND ROOF Company (India) Ltd to verify this statement.
- 3) The undersigned understands that further qualifying information may be requested and agrees to furnish any such information at the request of BRIDGE AND ROOF Company (India) Ltd.
- 4) Certified that I have applied in the tender in the capacity of individual / as a partner of a firm and I have not applied severally for the same job.
- 5) The undersigned do certify that our firm will install machineries at the site as per requirement of this NIT if selected as the executing agency of the work.
- 6) The undersigned do certify that our firm will engage required engineers as per requirement of this NIT if selected as the executing agency of the work.
- 7) The undersigned do certify that I/we shall not sublet any portion of the work.
- 8) The undersigned do certify that all the statements made in the attached documents are true and correct. If any declaration submitted is found/ascertain to be incorrect/ fabricated / misrepresented/fraudulent etc. accordingly tender will be liable to be cancelled/terminated immediately and I/my firm/company shall also be liable to prosecuted under section 197, 199 and 200 of Indian Penal Code, 1860 along with section 71 and Section 73 of Indian Information and Technology Act 2008 and any other applicable law for the time being in force in addition to forfeiture of Earnest Money/Retention Money.

Dated : _____

Signature of applicant including title and capacity in which application is made and the name of the Firm with Seal

BRIDGE AND ROOF CO. (INDIA) LIMITED
(A GOVERNMENT OF INDIA ENTERPRISE)
1st Floor, New Station Building, Platform No. 6
Santragachi, PIN- 711 111, West Bengal

EXECUTION OF RCC ROAD ALONG WITH FOOTPATH, DRAINAGE AND MISCELLANEOUS FINISHING WORK ON SUB-CONTRACT BASIS IN CONNECTION WITH "CONSTRUCTION OF NEW ISLAND PLATFORM AND REFURBISHING OF EXISTING PLATFORMS INCLUDING PLATFORM SHADE AT SANTRAGACHI RAILWAY STATION REGARDING STATION DEVELOPMENT WORK FOR SOUTH EASTERN RAILWAY IN WEST BENGAL.

NOTICE INVITING TENDER (NIT) No.:B AND R/51110/TD/SC/RCC ROAD WORK/01 DTD. 13/06/2024

ANNEXURE - III

GENERAL CONDITION OF CONTRACT(GCC)

GENERAL CONDITIONS OF CONTRACT

1.0 DEFINITIONS :-

In constructing these conditions, the specifications, the Schedule of Quantities & Rates, Tender and Agreement, the following words shall have the meanings hereby assigned to them except when the subject to context otherwise requires:

- 1.1 "Owner/ Client" shall mean "South Eastern Railway under Ministry of Railways", Government of India (here-in-after called SER) and shall include their authorized representatives, successors and permitted assigns as well as their authorized officer / representatives.
- 1.2 "WORK or CONTRACT WORK" shall mean and include supply of all categories of labour, specified consumables, tools and tackles and Plants required for complete and satisfactory site transportation, handling, stacking, storing, erecting, testing and commissioning of the equipments to the entire satisfaction of B&R & Owner
- 1.3 The "Employer" or "Company" shall mean Bridge And Roof Co. (I) Ltd. (hereinafter called B&R) employed by South Eastern Railway as an agency for "Execution of RCC Road along with Footpath, Drainage and miscellaneous Finishing work on Sub-Contract Basis in connection with "Construction of New Island Platform and Refurbishing of Existing platforms including platform shade at Santragachi Railway Station regarding Station Development work for South Eastern Railway in West Bengal."and shall include their authorized representatives, successors, permitted assigns.
- 1.4 "Acceptance of Tender" shall mean the Acceptance of Tender issued by the B&R & Owner to the Contractor and shall include a letter, telegram or fax of acceptance or other notification of award of work, and a detailed Letter of Acceptance.
- 1.5 "Approval" shall mean the written and signed approval of B&R's Engineer-in-Charge with respect to a plan or drawing, subject to the limitation(s) specified in such approval.
- 1.6 The "Accepting Authority" shall mean the authority mentioned in the Instruction to Bidders (Annexure – II).
- 1.7 Tenderer / Bidder shall mean the Firm / party who quotes against this enquiry.
- 1.8 The "Contractor/Sub-Contractor" shall mean the individual agency, Firm or Company (whether incorporated or not) selected by B&R for the performance of the Contract and shall include its legal representatives, successors and permitted assigns.
- 1.9 The "Contract" shall mean the Notice Inviting Tender, the Tender and acceptance thereof and the formal agreement, if any, executed between Bridge And Roof Co. (India) Ltd. and the Contractor together with documents referred to therein including their conditions with annexure(s) and any special conditions, the specifications, designs, drawings, schedule of quantities and amounts and schedule of rates. All these documents taken together shall be deemed to form the contract and shall be complementary to one another.
- 1.10 "Completion "or Final Completion" shall mean the successful provision of all material and inputs and the successful completion and conclusion of all activities required in all respects to complete the contractual works in accordance with the contract, but shall not include the obligation to rectify defects during the Defect Liability Period.
- 1.11 "Completion Certificate" shall mean the Completion Certificate issued by the Engineer-in-Charge in accordance with the provisions thereof.
- 1.12 "Consultant" shall mean the Consultant appointed by the owner for the Project or the Works.
- 1.13 "Consumables" shall mean all Items which are consumed in the execution of the work without being directly incorporated in the work, such as fuel, electricity, Water, POL, Welding rods, electrodes and utilities.

- 1.14 "Defect Liability Period" shall mean the defect liability period as specified in the contract and "maintenance Period" shall mean them maintenance Period as specified in the contract.
- 1.15 The "Engineer-in-Charge" shall mean the Engineer or other officer of the B&R for the time being nominated by the B&R in writing to act as Engineer-in-Charge for the purpose of the Contract or any specific works.
- 1.16 "GENERAL CONDITIONS OF CONTRACT" shall mean the 'Instructions to Tenderers' and 'General Conditions of Contract' pertaining to the work for which above tenders have been called for.
- 1.17 "TENDER SPECIFICATION" or "TENDER" or "TENDER DOCUMENTS" shall mean General Conditions, Special Conditions, Price Bid, Rate Schedule, Technical Specifications, Annexures, Corrigendum's, Amendments, Forms, procedures, Site information, etc and drawings/documents pertaining to the work for which the Tenderers are required to submit their offers. Individual specification number will be assigned to each Tender Specification.
- 1.18 'CONTRACT PRICE' shall mean the sum accepted or the sum calculated in accordance with the prices accepted in Tender or the contract rates as payable to the Contractor for the entire execution and full completion of work.
- 1.19 "LETTER OF INTENT" shall mean the intimation by a Letter / Fax / E-mail to the Tenderer that the tender has been accepted in accordance with provisions contained in the letter. The responsibility of the contractor commences from the date of issue of this letter and all terms and conditions of the contract are applicable from this date.
- 1.20 "COMPLETION TIME" shall mean the period by 'date/month' specified in the 'Letter of Intent' or date mutually agreed upon for handing over of the intended scope of work which are found acceptable by the Engineer, being of required standard and conforming to the specifications of the Contract.
- 1.21 "TESTS" shall mean and include such test or tests to be carried out on the part of the contractor as are prescribed in the contract or considered necessary by B&R/Owner in order to ascertain the quality, workmanship, performance and efficiency of the contractor or part thereof.
- 1.22 "TEMPORARY WORK" shall mean all temporary works for every kind required in or for the execution, completion, maintenance of the work.
- 1.23 "COMMENCEMENT DATE" or "START DATE" shall mean the commencement/start of work at Site as per terms defined in the Tender.
- 1.24 "SHORT CLOSING" or "FORE CLOSING" of Contract shall mean the premature closing of Contract, for reasons not attributable to the contractor and mutually agreed between B&R/Owner and the contractor.
- 1.25 "TERMINATION" of Contract shall mean the pre mature closing of contract due to reasons as mentioned in the contract.
- 1.26 "DE MOBILISATION" shall mean the temporary winding up of Site establishment by Contractor leading to suspension of works temporarily for reasons not attributable to the contractor.
- 1.27 "RE MOBILISATION" shall mean the resumption of work with all resources required for the work after demobilization.
- 1.28 "Final Certificate" shall mean the final certificate issued by the Engineer-in- Charge in accordance with the provisions hereof.
- 1.29 "Job Site" shall mean any site at which the work is to be performed by the Contractor, and shall include a part or part on of the job site.
- 1.30 "Materials" shall mean all materials, plant, machinery, instruments, components, equipments, sub-assemblies and assemblies, parts, spares and other items or things required for permanent incorporation in the works.
- 1.31 "Order" and "Instruction" shall respectively mean any written Order or Instruction given by the Engineer-in-Charge or Site Engineer within the Scope of their respective powers in terms of the Contract.
- 1.32 "Plans" and "Drawings" shall mean and include all technical documentation such as maps, sketches, designs, drawings, plans, details, charges, schedules, tracings, prints, computer outputs, printouts, and manuals, relating to the work forming the subject matter of the contract, including but not limited to those forming part of the tender

Documents, Offer Documents, and working drawings and details, together with amendments/ alterations/ revisions/ modifications thereto, as may have been approved by and/or furnished by B&R, the Engineer-in-Charge and/ or the consultant. as well as "As Built" drawings to be submitted by the Contractor as required under the contract.

- 1.33 "Progress Schedule" shall mean the Progress Schedule established by the Contractor and approved by the Engineer-in-Charge for completion of the work(s) within the time schedule in accordance with the provisions hereof and failing such Progress Schedule, shall mean the Progress Schedule established by the Engineer-in-Charge in accordance with the provisions hereof.
- 1.34 "Performance Test(s)" shall mean all tests meant to ensure that the Plant(s)/Unit(s) is/are in all respects in accordance with the requirements of the Contract and that the Plant functions properly and smoothly, in all respects as per the approved design parameters, within the permissible tolerances, and satisfies all the stipulated operating parameters, and will include the Guarantee Tests.
- 1.35 "Project" shall mean the project embracing the work(s) forming the subject matter of the Contract.
- 1.36 The "Site Engineer" shall mean the Engineer(s)/Officer(s) for the time being designated by the Engineer-in-Charge as his representative(s) in writing, and authorized by him to assist him in performing his duties and functions for the purpose of the Contract.
- 1.37 "Schedule of Rates" or "Price Schedule" shall mean the Schedule of Rates or Price Schedule annexed to the Acceptance of Tender, and shall also include a lump sum price.
- 1.38 The "Specification(s)" shall mean the various specifications as set out in the Specifications forming part of the Tender Documents and as referred to and derived from the Contract and any order(s) or instruction(s) there under, and in the absence of any specifications as aforesaid covering any particular work or part or portion thereof, shall mean the Specifications and Codes of the Bureau of Indian Standards and other Organizations, including but not limited to British Standards Institution, ASTM, ASME, ANSI, API, AWS, AWWA, NACE, HEI, IEC, IBR, IEEE, EII, CPWD, etc, with such modifications' as may be applicable for the particular part(s) of the Contract as decided by the Engineer-in-Charge and as per Standard Engineering and Industry Practice and/or as directed by the Engineer-in-Charge.
- 1.39 "Work", "Scope of Work", "Service", and "Scope of Services", shall mean the totality of the work, services and activities to be performed or undertaken and the totality of the responsibilities to be discharged, as envisaged by expression or implication in the contract and shall include all inputs required for such performance and discharge (including pre-construction activities). construction supervision, supply of consumables, labour, construction and other requisite machinery and equipments, utilities and inputs required for, relative or incidental to and/or in connection with the performance of the contract up to completion (including handing over, troubleshooting, rectification, maintenance and defect liabilities).
- 1.40 Work Order shall mean the Formal letter/notification issued to the Sub-Contractor awarding the work(s) in full or in part by the Company together with the applicable terms and conditions etc. as are finally and mutually agreed to between the Company and the Sub-Contractor.
- 1.41 Engineer-in-charge shall mean The officer/Engineer nominated and authorized by the company for the time being for the purpose of operating the contract or any work covered there under.

2.00 SCOPE OF WORK :

- 2.01 The work in general shall consist of Execution of RCC Road along with Footpath, Drainage and miscellaneous Finishing work on Sub-Contract Basis in connection with "Construction of New Island Platform and Refurbishing of Existing platforms including platform shade at Santragachi Railway Station regarding Station Development work for South Eastern Railway in West Bengal." to be carried out in accordance with the drawings and Schedule of Quantities & Rates.
- 2.02 It shall be clearly understood that the above list of scope of work is not conclusive and all incidental/ancillary works involved shall also become part of Contractor's scope.
The scope of work may also include such other related works as covered in the Schedule of Quantities and Rates although they may not be specifically mentioned in the above paragraphs and all such incidental items not specified but reasonably implied and necessary for the completion of the work as a whole or as directed by B&R.

B&R may in their absolute discretion issue further drawings and / or written instructions, details, directions and

explanations, which are, hereafter collectively referred to as "B&R's instructions" in regard to:

- 2.03 The Owner / Employer reserve the right to increase or decrease the scope of work and/or not to operate any one or more of the item (s) of work (s) of SOQR. It is the responsibility of the Contractor to ascertain from the Engineer-in-charge, the items to be operated with their actual quantities before making any arrangement (s) for taking up work under the item (s). No claim, whatsoever, from the Contractor will be entertained for non-operation of any of the item(s) or for variation in quantity of any of the item(s).
- 2.04 The Scope of Work may also include such other related works as covered in the 'Schedule of Quantities & Rates' although they may not be specifically mentioned in the above paragraphs and all such incidental items not specified but reasonably implied and necessary for the completion of the work as a whole, shall be deemed to be included in the quoted rates of the Contractor.
- 2.05 B&R reserves the right to split up the work included in the Scope of this tender among more than one Contractor at the stage of initial award or during the progress of work.
- 2.06 B&R also reserves the right to take away part of initially awarded work from the Contractor in case of his unsatisfactory work progress and award the same to other Agencies, in order to meet the time schedule of owner/client or for any other reason or contingency. In this regard B&R's decision will be final & binding on the contractor and contractor will not have any claim whatsoever in this regard.

3.00 GENERAL INFORMATION & SITE INSPECTION :

3.01 Introduction:

Execution of RCC Road along with Footpath, Drainage and miscellaneous Finishing work on Sub-Contract Basis in connection with "Construction of New Island Platform and Refurbishing of Existing platforms including platform shade at Santragachi Railway Station regarding Station Development work for South Eastern Railway in West Bengal. Detailed scope of work is defined elsewhere in the tender.

3.02 Site Location:

The work site is situated at the premises of Santragachi Railway Station, Santragachi, Howrah, West Bengal- 711111 at a distance of 10 K.M. approximately from Howrah Railway Station, 15 K.M. approximately from Esplanade, Kolkata & 28.5 K.M. approximately from Dum Dum International Airport, Kolkata. Tenderers are advised to inspect and examine the site and its surroundings and satisfy themselves before submission of their offer about the conditions of site, the nature of work, means and access to the site, accommodation they may require and all other necessary information as to the risks, contingencies and other circumstances which may influence or affect their offer and work. A tenderer shall be deemed to have full knowledge of the site whether he inspects it or not and no extra charges consequent to any misunderstanding or otherwise shall be allowed.

3.03 Site Visit & Inspection :

The Bidder shall visit and inspect the site and its surroundings and shall satisfy himself before submitting his quotation as to the nature of the ground and sub soil (so far as is practicable) the form and nature of the site and nature of work and materials necessary for the execution of the work, and the means of access to the site, the accommodation he may require and in general shall himself obtain all necessary information as to risks, contingencies and other circumstances which may influence or affect his quotation. No extra charges consequent on any is understanding or otherwise shall be allowed.

3.04 **For site visit the Tenderer may contact with our Sri Bikash Sarkar, Resident Manager (IRCON-Santragachi) Civil, Mob. No.: -9051945666.**

3.05 Local Conditions:

It will be imperative on the part of each bidder to acquaint himself with all local laws, conditions and factors which may have any effect or bearing on the execution of works under the scope of this tender. In their own interest, the bidders are required to familiarize themselves with (but not limited to) the Indian Income Tax Act, Indian Companies Act, Indian Customs Act, Factories and Boiler Act, Contract Labour (regulation and abolition) Act, Arbitration Act, PF Act, ESIC Act and other related Acts and Laws and Regulations of India with their latest amendments as applicable. The successful Bidder, to whom the work shall be awarded, shall arrange such permissions on his own initiative and contingent costs thereto. B&R shall not entertain any clarification from the Bidder(s) regarding such local conditions.

Considering the above, Tenderers are advised to inspect and examine the site and its surroundings and satisfy

themselves before submission of their offer as to the nature of the site and Sub-Soil, the quantities and nature of work and materials necessary for completion of the works and the means and access to the site, accommodation they may require and all other necessary information as to the risk, contingencies and other circumstances which may influence or affect their offers and work. A tenderer shall be deemed to have full knowledge of the Site whether he inspects it or not and no extra charge consequent to any misunderstanding or otherwise shall be allowed.

4.00 SCHEDULE OF QUANTITIES & RATES:

The quantities for various items of works as shown in the Schedule of Quantities & Rates of probable items of works are based on the basic design drawing prepared and issued by B&R's Client. However, if quantity variations become necessary due to Design consideration / Site conditions etc. those have to be done by the contractor at the time of execution of work at their finally accepted rates(s). **No conditional rate will be allowed in any case.**

5.00 EARNEST MONEY DEPOSIT

Rs. 4.36 Lakhs shall be submitted by Bidder(s) along with their offer in the form of Demand Draft (D.D.) / Pay Order / Banker's Cheque valid for minimum 90 (Ninety) days / Bank Guarantee (BG) in prescribed format valid for minimum 06 (Six) months pledged in favour of "BRIDGE AND ROOF Co. (India) Ltd" drawn from any Nationalized/Scheduled Bank, in favour of BRIDGE AND ROOF Co. (I) Ltd., payable at Kolkata shall be submitted along with Tender documents. (No A/c Payee Cheque shall be considered).

EMD amount in the form of BG submitted by Successful Bidder(s) shall be retained till submission of valid BG towards Performance Guarantee and the same shall be released thereafter. EMD amount in the form of Demand Draft (D.D.) / Pay Order / Banker's Cheque submitted by Successful Bidder(s) will be treated as a part of Security Deposit / Retention Money and the deduction towards the Security Deposit / Retention Money will be started after adjustment of EMD amount against value of work done in R/A bills. EMD amount of Un-Successful Bidder(s) shall be returned to them at the earliest after expiry of the final bid validity and latest on or before the 30th day after the award of the Contract. However, EMD amount of Un-Successful Bidder(s) during First Stage i.e. Technical Evaluation etc. should be returned within 30 days of declaration of result of First Stage i.e. Technical Evaluation. No interest will be payable on Earnest Money Deposit.

Exemption of Tender Fee & EMD will not be applicable as per PP Policy, 2012, works contract are not covered under PP Policy as per Letter no. 190/Mech/Cores/Various org/Stakeholder/2021-22 dated 18/19-04-2022. The offer of the bidder shall not be considered further if the Cost of Tender Document is not submitted in the form and manner as stated above and their offer is liable to be rejected.

6.00 QUANTITY VARIATION:

The Quantities indicated in SOQR are approximate and those may vary upward and downward to any extent within the quoted rate of the bidder and such variation over contract quantities shall not be liable for any additional claim. However, the total Contract Price may vary up to $\pm 25\%$ due to increase or decrease in the executed Quantities.

7.00 DEMURRAGE AND WHARFAGE DUES :

Demurrage charges calculated in accordance with the scale in force for the time being on B&R and incurred by the Contractor failing to load or unload any goods of materials within the time allowed by B&R for loading as also wharfage charges, of materials not removed in time as also charges due on consignments booked by or to him shall be paid by the Contractor, failing which such charges shall be debited to the Contractor's account in the hands of B&R and shall be deducted from any sums which may become due to him in terms of the contracts.

8.00 DISPOSAL OF SURPLUS MATERIALS:

8.01 The contractor shall at all time keep the site free from all surplus earth, surplus materials, and all rubbish which shall arise from the works and should dispose of the surplus materials as ordered by the Engineer failing which it will be done at the cost of the contractor and cost will be deducted from his dues.

8.02 The contractor shall within 15 days of completion of entire works remove all unused and surplus materials tools and plants staging and refuge or other materials produced by his operations and shall leave the site in a clear and tidy conditions.

9.00 LABOUR:

9.01 The Contractor shall employ labour in sufficient numbers to maintain the required rate of progress and quality to ensure workmanship of the degree specified in the Contract and to the satisfaction of the Engineer-in-Charge. The Contractor shall not employ in connection with the Works any person who has not completed his Eighteen (18) years of age.

- 9.02 The Contractor shall furnish to the Engineer-in-Charge at the intervals mentioned by Engineer-in-Charge, a distribution return of the number & description by trades of the workpeople employed on the Works. The Contractor shall also submit on the 4th and 19th of every month to the Engineer-in-Charge a true statement showing in respect of the second half of the current month (i) the accidents that occurred during the said fortnight showing the circumstances under which they happened and the extent of damage and injury caused by them and (ii) the number of female workers who have been allowed Maternity Benefit as provided in the Maternity Benefit Act, 1961 of Rules made thereunder and the amount paid to them.
- 9.03 The Contractor shall pay to labour employed by him wages not less than fair wages as defined in the Contractor's Labour Regulations.
- 9.04 The Contractor shall in respect of labour employed by him comply with or cause to be complied with the Contractor's Labour Regulations in regard to all matters provided therein.
- 9.05 The Contractor shall comply with the provisions of the payment of Wages Act, 1936, Minimum Wages Act, 1948, Employer's Liability Act, 1938, Workmen's Compensation Act, 1923, Industrial Disputes Act, 1947, Maternity Benefit Act, 1961 and Mines Act, 1952 or any modifications thereof or any other law relating thereto and rules made thereunder from time to time.
- 9.06 The Contractor shall be liable to pay his contribution and the employee's contribution to the State Insurance Scheme in respect of all labour employed by him for the execution of the contract, in accordance with the provision of "The Employee's State Insurance Act, 1948" as amended from time to time. In case the contractor fails to submit full details of his account of labour employed and the contribution payable, the Engineer-in-Charge shall recover from the running bills of Contractor and amount of contribution as assessed by him. The amount so recovered shall be adjusted against the actual contribution payable for Employees State Insurance.
- 9.07 The Engineer-in-Charge shall on a report having been made by an Inspecting Officer as defined in the Contractor's Labour (Regulation and Abolition) Act 1970 have the power to deduct from the money due to the Contractor any sum required or estimated to be required for making good the loss suffered by a worker or workers by reasons of non-fulfilment of the Conditions of the Contract for the benefit of workers, non-payment of wages or of deduction made from his or their wages which are not justified by the terms of the Contract or non-observance of the said Contractor's Labour Regulations and Acts 1910 and Rules framed there under.
- 9.08 In the event of the Contractor committing a default or breach of any of the provisions of the aforesaid contractor's Labour Regulations, as amended from time or furnishing any information of submitting or filling any Form / Register / Slip under the provisions of these Regulations which is materially incorrect then on the report of the Inspecting Office as defined in the Contractor's Labour Regulation, the Contractor shall without prejudice to any other liability pay to the Company a sum as applicable as per prevailing Rules as liquidated damages for every default, breach or furnishing, making, submitting, filling materially incorrect statement as may be fixed by the Engineer-in-Charge & in the event of the Contractor's default continuing in this respect, the liquidated damages may be enhanced for each day of default subject to a maximum percent of the estimated cost of the Works put to tender. The Engineer-in-Charge shall deduct such amount from bills or security deposit of the Contractor and credit the same to the Welfare Fund constituted under Regulations. The decision of the Engineer-in-Charge in this respect shall be final and binding.
- 9.09 The Contractor shall at his own expense comply with or cause to be complied with Model Rules for Labour Welfare framed by Government from time to time for the protection of health and for making sanitary arrangements for workers employed directly or indirectly on the Works. In case the Contractor fails to make arrangement as aforesaid, the Engineer-in-Charge shall be entitled to do so and recover the cost thereof from the Contractor.
- 9.10 The Contractor shall at his own expense arrange for the safety provisions as required by the Engineer-in-Charge, in respect of all labour directly or indirectly employed for performance of the Works and shall provide all facilities in connection therewith. In case the Contractor fails to make arrangements and provide necessary facilities as aforesaid, the Engineer-in-Charge shall be entitled to do so and recover the cost thereof from the Contractor.
- 9.11 Failure to comply with Model Rules for Labour Welfare, Safety Code or the provisions relating to report on accidents and to grant of maternity benefits to female workers shall make the Contractor liable to pay to the Company as liquidated damages as applicable as per prevailing Rules for each default or materially incorrect statement. The decision of the Engineer-in-Charge in such matters based on reports from the Inspecting Officers as defined in the Contractor's Labour Regulation as appended to these conditions shall be final and binding and deductions for recovery of such liquidated damages may be made from any amount payable to the Contractor.

10.00 SITE INSPECTION REGISTER:

10.01 A site inspection register will be maintained by the Engineer or his representative in which the contractor will be bound to sign day to day entries made by the Engineer or his representative. The contractor is required to take note of the instructions given to him through the site inspection register and should comply with the same within a reasonable time. The contractor will also arrange to receive all the letters etc. issued to him at the site of works.

10.02 The contractor shall, from time to time (before the surface of any portion or the site is interfered with or the work thereon begun) take such levels as the Engineer may direct in his presence or any person authorized by him in writing. Such levels approved and checked by him or such authorized persons shall be recorded in writing and signed by the contractor and shall form the basis of the measurements. Immediately before any portion of the work, below water level is started, the existing water levels are to be taken and recorded in a similar manner.

10.03 The contractor shall have to make and maintain at his own cost suitable approach road and path, etc for proper inspection of the various works. He shall also provide all facilities as required by the Engineer such as Ladder and other appliances for satisfactory inspection of the works and places where materials for the work are stored or prepared.

11.00 ILLEGAL GRATIFICATION:

11.01 Any bribe, commission, gift or advantage given, promised or offered by or on behalf to the Contractor or his partner, agent or servant or, anyone on his behalf, to any officer or employee of B&R, or to any person on his behalf in relation to obtaining or execution of this or any other contract with B&R shall, in addition to any criminal liability which he may incur, subject contractor to the rescission of the contract and all other contracts with B&R and to the payment of any loss or damage resulting from such decision and B&R shall be entitled to deduct the amounts so payable from any moneys due to the Contractor(s) under this contract or any other contracts with B&R.

11.02 The Contractor shall not lend or borrow from or have or enter into any monetary dealings or transactions either directly or indirectly with any employee of B&R and if he shall do so, B&R shall be entitled forthwith to rescind the contract and all other contracts with B&R. Any question or dispute as to the commission or any such offence or compensation payable to B&R under this Clause shall be settled by the General Manager of B&R, in such a manner as he shall consider fit & sufficient and his decision shall be final & conclusive. In the event of rescission of the contract under this Clause, the Contractor will not be paid any compensation whatsoever except payments for the work done upto the date of rescission.

12.00 WORKMANSHIP AND TESTING:

The whole of the works and/or supply of materials specified and provided in the contract or that may be necessary to be done in order to form and complete any part thereof shall be executed in the best and most substantial workman like manner with materials of the best and most approved quality of their respective kinds, agreeable to the particulars contained in or implied by the specifications and as referred to in and represented by the drawings or in such other additional particulars, instructions and drawings may be found requisite to be given during the carrying on of the works and to the entire satisfaction of the Engineer-in-charge according to the instructions and directions which the Contractors may from time to time receive from the Engineer-in-charge. The materials may be subjected to tests by means of such machines, instruments and appliances as the Engineer-in-charge may direct and wholly at the expense of the Contractor.

13.00 REMOVAL OF IMPROPER WORK AND MATERIALS:

The Engineer or the Engineer-in-charge's Representative shall be entitled to order from time to time:

- (a) The removal from the site within the time specified in the order of any materials which in his opinion are not in accordance with the specifications or drawings.
- (b) The substitution of proper and suitable materials, and
- (c) The removal and proper re-execution, notwithstanding any previous tests thereof or on account payments therefore, of any work which in respect of materials or workmanship is not in his opinion in accordance with the specifications and in case of default on the part of the Contractor in carrying out such order, B&R shall be entitled to rescind the contract

14.00 PROVISION OF LIGHT SIGNALS ETC:

14.01 The contractor/s shall make such provision for lighting the works, materials and plant and provide all such marks and lights, signals and other appliances as may be necessary or as may be required by the Engineer or other responsible authorities during the execution completion and maintenance of the work and shall provide all labour, stores, etc. required for their efficient working and use at any time of day or night. He/They shall also provide all arrangement of every description of watching and maintenance required in connection with the foregoing and all other services for

protection of any securing all dangerous places whether to the contractor's workmen or to other persons and or vehicular traffic until the work is certified by the engineer to have been completed and taken over in accordance with the contract.

14.02 The contractor/s will provide upon the works to the satisfaction of the Engineer and at such, places as he may nominate, proper and sufficient life saving, fire fighting and first aid appliances which shall at all times be available for use.

15.00 **DRAWING AND SPECIFICATION:**

a. Entire work has to be carried out in accordance with the technical specification as given along with tender document issued by B&R.

b. Entire work has to be carried out in accordance with the drawings which will be issued time to time, if any, by B&R.

16.00 **SUFFICIENCY OF QUOTATION:**

The Bidder shall be deemed to have satisfied himself before tendering as to the correctness and sufficiency of his quotation for the works and of the rates and prices quoted in the Schedule of Quantities which rates and prices shall, except as otherwise provided, cover all his obligations and liabilities under the Contract and all matters and things necessary for the proper completion and maintenance of the Works.

17.00 **SECURITY DEPOSIT / RETENTION MONEY:**

i) Retention money for above contract shall be recovered from on account/ final bills of the Contractor @ 10% of gross value of each bill after adjusting EMD amount till the amount so recovered including EMD amount adds upto 5% of the contract value of the work.

ii) The Retention Money shall be released without any interest to the Contractor after preparation of final bill and acceptance of the same by the Contractor and after the expiry of the defect liability period specified in the Contract, reckoned from the date on which the Certificate of Completion of works has been issued. The retention money shall be released after all failures, defects, imperfections, shrinkages and faults have been rectified by the Contractor to the satisfaction of the Project Consultant / Engineer and Defect Liability certificate is issued by the Employer.

18.00 **DEFECTS LIABILITY PERIOD:**

The Contractor shall guarantee and maintain the works for a period of **365 days or one monsoon whichever is later**. The Contractor shall be responsible to make good and remedy at his own expenses within such period as may be stipulated by the Engineer-in-Charge, any defect which may develop or may be noticed before the expiry of Defect Liability Period/ Maintenance period.

19.00 **RATES FOR PAYMENT:**

The rates given in the attached schedule of rates tendered by the contractor and as accepted by the B&R will form the basis of payment for such items under this contract.

20.00 **COMPLETION TIME:**

20.01 Unless otherwise specified by B&R the Contractor is required to commence the work **within 07 (Seven) days** from the date of issue of Letter of Intent by B&R.

20.02 Time is the essence of the contract. Entire work as detailed in tender specification shall be completed within **02½ (Two and Half) months** from the date of issuance of LOI or handing over the Site, whichever is later as per detail programs to be indicated by B&R in due course of time. Contractor has to mobilize adequate resources to meet B&R's commitments to client as indicated from time to time.

20.03 In case due to reasons not attributable to the Contractor, the work gets delayed and scheduled date of completion gets extended, time extension will be granted by B&R but in no case over run compensation will be payable. Contractor shall be bound to execute the works under extended period in all respects at the same rates, terms & conditions.

20.04 The work under the scope of this contract is deemed to be completed in all respects, only when all the works are carried out as per satisfaction of Engineer-in-Charge of B&R. The decision of Engineer-in Charge of B&R on completion date shall be final and binding on the Contractor.

21.00 **LABOUR GATE PASS ISSUES RELATED TO LABOUR UNION**

The contractor shall provide all the documents necessary for labour gate pass and shall be responsible to sort out all the problems regarding gate pass and local labour unions of different nature.

22.00 **DELAY IN EXECUTION OF WORK:**

If the works be delayed by:

- (a) Force major or
- (b) Abnormally bad weather, or
- (c) Serious loss or damage by fire, or
- (d) Civil commotion, local combination of workmen, strike or lock out affecting any of the trades employed on the work, or
- (e) Delay on the part other Contractors of tradesman engaged by Company in executing work not forming part of the contract, or
- (f) non-availability of stores, which are the responsibility of Company to supply, or
- (g) non-availability or break-down of tools & plants to be supplied or supplied by company, or
- (h) any other cause which in the absolute discretion of Engineer-in-charge is found as beyond the Contractor's control, then upon the happening of any such event causing delay, the Contractor shall immediately give notice thereof in writing to the Engineer-in-Charge but shall nevertheless use constantly his best Endeavour's to prevent or make good the delay and shall do all that may be reasonably required to the satisfaction of the Engineer-in-Charge to proceed with the works.

23.00 **MATERIALS**

In case, the Sub-Contractor fails to procure and supply of required quantity of materials which is within Sub-Contractor's scope of supply in commensurate with scheduled program to achieve required progress, the B&R at its own discretion shall arrange to supply to the Sub-Contractor materials on chargeable basis, the rates of which will be derived at the landed cost + 10% (ten percent) thereon towards service charge and the same will be recovered from Sub-Contractor's bills.

The Contractor shall at his own expense, provide all materials required for the work .All materials to be provided by the Contractor shall be in conformity with the specifications laid down in the contract and the Contractor shall, if requested by the Engineer-in-Charge, furnish proof to the satisfaction of him that the materials so comply.

The Contractor shall, at his own expense and without delay, supply to the Engineer-in-Charge samples of materials proposed to be used in the works. The Engineer-in-Charge shall within seven days of supply of samples or within such further period as he may require intimate to the Contractor in writing/inform the Contractor whether samples are approved by him or not. If samples are not approved, the Contractor shall forthwith arrange to supply to the Engineer-in-Charge for his approval fresh samples complying with the specification laid down in the Contract.

The Engineer-in-Charge shall have full powers for removal of any or all the materials brought to site by the Contractor which are not in accordance with the Contract specifications or do not conform in character or quality to samples approved by him. In case of default on the part of the Contractor in removing rejected materials the Engineer-in-Charge shall be at liberty to have them removed by other means. The Engineer-in-Charge shall have full powers to procure other proper materials to be substituted for such rejected materials and in the event of the Contractor refusing to comply, he may arrange to supply by other mean. All costs, which may attend upon such removal and/or substitution, plus 10% (Ten Percent) towards service charge of B&R shall be borne by the Contractor.

All charges on account of transportation, octroi, terminal or GST and other duties on materials obtained for the works from any source (including materials supplied by the Company) shall be borne by the Contractor.

24.00 **CONSUMABLES:**

The Contractor shall arrange at his own cost all consumable (Like welding electrodes, DA & Oxygen, Binding wires, Nails etc.) required for execution of his works. For execution of any item of works of bill of quantity, if it is found that the Contractor has failed to arrange the consumable commensurate to work programme, B&R shall then provide to the Contractor the necessary consumables and recover from the running account bills as per instruction of Engineer-in-Charge.

25.00 TOOLS, PLANTS & EQUIPMENTS

Providing of all tools & tackles, machineries, plant and equipment etc. required for satisfactory execution & completion of the work shall be under the scope of the sub-contractor within the quoted rate. All cost of fuel and stores for proper running of the Tools and Plants must be borne by the Contractor.

26.00 APPROVAL OF SAMPLE

Samples of all materials to be supplied by the Sub-Contractor and to be used in the work shall have to be approved by the Engineer-in-Charge and checking the quality of such materials shall have to be done as directed by Engineer-in-Charge prior to utilization in the work.

27.00 SUB – CONTRACT:

The Contractor shall not sublet any portion of the contract without the prior written approval of the Accepting Authority.

28.00 ALTERATION IN THE SCOPE OF WORK:

28.01 B&R may, at any time(s) before or after the commencement of the work, by notice in writing issued to the Contractor, alter the scope of work by increasing or reducing the works or the jobs required to be done by the Contractor or by adding thereto or omitting there from any specific works or jobs or operations or by substituting any existing works or jobs or Operations with other works or jobs and / or operations, or by requiring the Contractor to perform any additional works in or about the job site, and upon receipt of such notice, the Contractor shall execute the job(s) as required within the altered scope of work.

28.02 If any alteration in the scope of work shall in the opinion of the Contractor, necessitate any extension in the time for completion, the provisions of Clause of SCC hereof and associated clauses with regard to the extension of time shall apply.

(a) If such alteration shall, in the opinion of the Engineer-in-Charge (whose opinion in this behalf shall be final and binding upon the Contractor, necessitate the performance of any work not covered by the Schedule of Rates, the remuneration for such work or portion or item thereof not covered by Schedule of Rates shall be determined in accordance with the provisions of relevant clauses of contract.

(b) If in the opinion of the Engineer-in-Charge (whose opinion in this behalf shall be final and binding upon the CONTRACTOR any alteration in the scope of the work shall result in any reduction or increase or change in the work or supply covered by the lump sum price so as to render unreasonable the lump sum price, the lump sum Price shall be increased or reduced, as the case may be, in accordance with Clauses of contract.

29.00 COMPENSATION FOR DELAY/ LIQUIDATED DAMAGES:

The extension of time for completion of the work shall be governed by Clause 17-A & 17-B of the General Condition of Contract (GCC) -2014 of SE Railway amended upto the date of issue of NIT, and the contractor shall be responsible for requesting such extension in terms thereof. B&R/IRCON may, if satisfied that the works can be completed by the contractor within reasonable short time thereafter, allow the contractor for further extension of time as the Engineer may decide. On such extension B&R/IRCON will be entitled without prejudice to any other right and remedy available on that behalf, to recover from the contractor as agreed damages and not by way of penalty a sum equivalent to ½ of 1% of the contract value of the works for each week or part of the week.

B&R shall deduct the amount of such compensation from any money due or which may become due to the contractor and/or recover such compensation from the bank guarantees / earnest money / retention money of the contractor. To be entitled to impose such compensation, B&R will not be required to prove that he has incurred such amount as actual damage.

30.00 STRIKES & LOCKOUT:

The Contractor will be fully responsible for all disputes and other issues connected with his labour. In the event of the Contractor's labour resorting to strike or the Contract or resorting to lock out and if the strike or lockout declared is not settled within a period of one month, B&R shall have the right to get the work executed through any other agencies and the cost so incurred by B&R shall be deducted from the Contractor's bills.

31.00 **SEQUENCE OF WORK:**

Contractor shall plan the sequence of all works so as to achieve the desired progress keeping in mind overall safety and stability at all points of time.

If due to a particular design or specification or availability of machines or any other reason, a particular sequence of operation is demanded by the engineer due to which some interruptions are inherent to anyone or more types of work or items of execution, then no claim for such interruption shall be entertained and Contractor shall have to follow the sequence as instructed by the engineer.

32.00 **DEPLOYMENT OF LABOUR & SUPERVISORY PERSONNEL:**

The quoted rates given in the Schedule of Quantities & Rates are inclusive of the Contractor's rate to provide all labours, and he shall thereof, deploy and engage, within the quoted rates, all categories of skilled/semi-skilled/unskilled workmen as required, directly or indirectly for the execution or completion of the works in all respect in a perfectly workmanship like manner as per approved specifications, drawings and the Time Schedule/Programme of Completion.

33.00 **SUPERVISORY PERSONNEL:**

The Agency shall depute adequate number of experienced Supervisors necessary for carrying out of the work maintaining good quality and satisfaction of Engineer in Charge.

If at any point, it is observed by the Company that, deployment of supervisory personnel is inadequate and the progress of work is affected, the Company shall engage Supervisors for the Agency's work at Agency's risk and cost. The cost incurred by the Company shall be recovered from the Agency's Running Account Bills.

34.00 **INSPECTION OF WORK:**

Client/Consultant/B&R's Engineer and Company's representatives will have full power and authority to inspect the works at any time whenever in progress whether at site or at Contractor's premises and the contractor shall afford and procure for them every facility and assistance required to carry-out such inspection and shall make available to them free of cost.

35.00 **INSTRUCTIONS & NOTICES:**

- (i) Subject or otherwise provided in this Contract, all notices to be given on behalf of the Employer and all other actions to be taken on its behalf may be given or taken by the Engineer-in-Charge or any officer for the time being entrusted with the functions, duties and power soft he Engineer-in-Charge.
- (ii) All instructions, notice and communication etc. under the Contract shall be given in writing and if sent by registered post to the last known place of above business of the Contractor shall be deemed to have been served on the date when in the ordinary course of post these would have been delivered to him.
- (iii) The Contractor or his Agent shall in attendance at the Site(s) during all working hours and shall superintend the execution of the works with such additional assistance in each trade as the Engineer-in-Charge may consider necessary. Orders given to the Contractor's Agent shall be considered to have the same force as if they had been given to the Contractor himself.

36.00 **LIABILITY FOR DAMAGE DEFECTS OF IMPERFECTION AND RECTIFICATION THEREOF:**

If the Contractor or his workmen or employees shall in jure or destroy any part of the building in which they may be working or any building, road, fence etc. contiguous to the premises on which the work or any part of it is being executed, or if any damage shall happen to the work while in progress the Contractor shall upon receipt of a notice in writing in that behalf make the same good at his own expenses.

37.00 **INSPECTION & APPROVAL:**

37.01 All works embracing more than one process shall be subjected to examine & approval at each stage thereof and the Contractor shall give due notice to the Engineer-in-Charge or his authorized representative when each stage is ready. In default of such notice, the Engineer-in-charge shall be entitled to appraise the quality and extent thereof.

Employer's/Client's representatives concerned with the Contract shall have power sat any time to inspect and examine any part of the works and the Contractor shall give such facilities as may be required for such inspection and examination.

- 37.02 No work shall be covered up or put out of view without the approval of the Engineer-in-Charge or his authorized representative and the Contractor shall afford full opportunity for examination of work before permanent work is placed thereon. The Contractor shall give due notice to the Engineer-in-Charge or his authorized representative whenever any such work is ready for examination and the Engineer-in-Charge or his representative shall without unreasonable delay, unless he considers it unnecessary and advises the Contractor accordingly, attend for the purpose of examining and measuring such work or of examining such foundations. In the event of the failure of the Contractor to give such notice he shall, if required by the Engineer-in-Charge, uncover such work at the Contractor's expense.
- 37.03 Company's/Owner's representatives concerned with the Contract shall have powers at any time to inspect and examine any part of the works and the Contractor shall give such facilities as may be required for such inspection and examination.
- 38.00 **REMOVAL OF WORKMEN:**
The Contractor shall employ in and about the execution of the works only such persons as are skilled and experienced in their several trades and the Engineer-in-Charge shall be at liberty to object to and require the Contractor to remove from the works any persons employed by the Contractor in or about the execution of the works who in the opinion of the Engineer-in-Charge misconducts himself or is incompetent or negligent in the proper performance of his duties and such person shall not be again employed upon the works without permission of the Engineer-in-Charge.
- 39.00 **WORK DURING NIGHT OR ON SUNDAYS & HOLIDAYS:**
Subject to any provisions to the contrary contained in the Contract, none of the permanent works shall be carried out during night or on Sundays or on authorized Holidays without the permission in writing of the Engineer-in-Charge except when the work is unavoidable or absolutely necessary for the safety of life, property of works in which case the Contractor shall immediately advise the Engineer-in-Charge accordingly.
- 40.00 **COMPLETION CERTIFICATE:**
As soon as the work is completed, the Contractor shall give notice of such completion to the Engineer-in-Charge and within a reasonable period of receipt of such notice the Engineer-in-Charge shall inspect the work and shall furnish the Contractor with a certificate of completion indicating (a) the date of completion (b) defects to be rectified by the Contractor and/or (c) items for which payment shall be made at reduced rates. When separate periods of completion have been specified for items or groups of items, the Engineer-in-Charge shall issue separate completion certificates for such item or groups of items.
- 41.00 **NOTICES TO LOCAL BODIES:**
(i) The Contractor shall comply with and give all notice required under any Governmental authority, instrument, rule or order made under any Act of parliament, State laws or any regulation of bye laws of any local authority relating to the works. He shall before making any variation from the Contract necessitated by such compliance give to the Engineer-in-Charge a written notice giving reasons for the proposed variation and obtain the Engineer-in-Charge's instruction therein.
(ii) The Contractor shall pay and indemnify the Company against any liability in respect of any fees or charges payable under any Act of Parliament, State laws or any Government instrument, rule or order and any regulations or bye-laws of any local authority in respect of works.
- 42.00 **FORECLOSURE :**
If at any time after acceptance of the tender, the Company shall decide to abandon or reduce the scope of the works for any reason whatsoever & hence not require the whole or any part of the works to be carried out, the Engineer-in-charge shall give notice to that effect to the contractor & the Contractor shall have no claim to any payment of compensation or otherwise, whatsoever, on account of any profit or advantage which he might have derived from the execution of the works in full but which he did not derive in consequence of the foreclosure of the whole or part of the works.
- 35.1 The contractor shall be paid at Contract Rates full amount for work as per percentage break up of item rates executed at site.
- 35.2 The contractor shall, if required by the Engineer-in-Charge, furnish to him books of account, wage books, time sheets and other relevant documents as may be necessary to enable him to certify the reasonable amount payable under this condition.

43.00 TERMINATION OF CONTRACT FOR DEATH:

If the Contractor is an individual or a proprietary concern and the individual or the proprietor dies and if the Contractor is a partnership concern and one of the partners dies then unless the Accepting Authority is satisfied that the legal representatives of the individual Contractor or of the proprietor of the Proprietary concern and in the case of partnership, the surviving partners, are capable of carrying out and completing the Contract, the Accepting Authority shall be entitled to cancel the Contract as to its in completed part without the Company being in any way liable to payment of any compensation to the estate of the deceased Contractor and/or to the surviving partners of the Contractor's firm on account of the cancellation of the Contract. The decision of the Accepting Authority that the legal representatives of the deceased to the surviving partners of the Contractor's firm cannot carry out and complete the Contract shall be final and binding on the parties. In the event of such cancellation the Company shall not hold the estate of the deceased Contractor and/or the surviving partners of the Contractors firm liable in damaged for not completing the Contract.

44.00 RECORDS & MEASUREMENT:

- (i) The Engineer-in-Charge shall except as otherwise stated ascertain and determine by measurement the value in accordance with the Contract or work done in accordance therewith.
- (ii) All items having a financial value shall be entered in Measurement book, level book etc. prescribed by the company so that a complete record is obtained of all work performed under the contract.
- (iii) Measurement shall be taken jointly by the Engineer-in-Charge or his authorized representative and by the Contractor or his authorized representative & the same should be Certified/Accepted by Owner.
- (iv) Before taking measurements of any work the Engineer-in-Charge or the person deputed by him for the purpose shall give a reasonable notice to the Contractor. If the Contractor fails to attend or send an authorized representative for measurement after such a notice or fails to countersign or to record the objection within a week from the date of measurement, then in any such event measurement taken by the Engineer-in-Charge or by the person deputed by him shall be taken to be correct measurements of the work.
- (v) The Contractor shall without extra charge provide assistance with every appliance labour, and other things necessary for measurement.
- (vi) Measurements shall be signed and dated by both parties each day on the site on completion of measurement. If the contractor objects to any of the measurement recorded on behalf of the Company a note to that effect shall be made in the Measurement Book against the item objected to and such note shall be signed and dated by both parties engaged in taking the measurement.

45.00 METHODS OF MEASUREMENT:

Except where any general or detailed description of the work in quantities expressly those to the contrary, Schedule of Quantities shall be deemed to have been prepared and measurements shall be taken in accordance with the procedure set forth in the Schedule of Quantities/Specification notwithstanding any provision in the relevant standard method of Measurement or any general or local custom.

46.00 ON ACCOUNT PAYMENT:

- (i) Interim bills shall be submitted by the Contractor at intervals as to be specified on or before the date fixed by the Engineer-in-Charge for the work executed. The Engineer-in-Charge shall then arrange to have the bill verified by taking or causing to be taken, where necessary, the requisite measurements of the work.
- (ii) Payment on account for amount admissible shall be made on the Engineer-in-Charge certifying the sum to which the Contractor is considered entitled by way of interim payment.
- (iii) Any interim certificate given relating to work done or materials delivered may be modified or corrected by any subsequent interim certificate or by the final certificate. No certificate of the Engineer-in-Charge supporting an interim payment shall of itself be conclusive evidence that any work or materials to which it relates is/are in accordance with the contract.
- (iv) Pending consideration of extension of date of completion interim payments shall continue to be made as herein provided
- (a) All payment will be made only once in a month against submission of invoice by the agency along with all relevant document from our Site by RTGS/E-Payment & for the same following to be furnished.
Name of Company :

Name of Bank :
Name of Branch :
City :
Account Number :
Account Type :
IFSC of the Bank Branch :
MICR Code of the Bank Branch :

- (b) Sub-Contractor within his quoted rates shall make necessary statutory payments of ESIC, PF as applicable as on date of any modification thereof time to time.
- (c) Payment will be made by 30 (thirty) working days from the date of certification of the R.A. bill by B&R Engineer-in-charge after receive of corresponding payment from Client against the same executed job.

47.00 FINAL BILL PAYMENT:

The final bill shall be submitted by the Sub-Contractor within three months of physical completion of the works.

No further claims shall be made by the Sub-Contractor after submission of the final bill and these shall be deemed to have been waived and extinguished. Payment of those items of the bill in respect of which there is no dispute and of items in dispute, for quantities and at rates as approved by Engineer-in-Charge, shall be made within the period specified.

48.00 INCOME TAX :

Income Tax will be deducted by cash at source from Contractor's all bills as per Income Tax Act & Rules framed there under at such rates as may be applicable from time to time.

49.00 LABOUR CESS:

1 (One) % Labour cess to be deducted from contractor's Running Bill.

50.00 NEW LEVIES/TAXES

In case Government imposes any new levy/tax after award of the work during the tenure of the contract, B&R shall reimburse the same at actual on submission of documentary proof of payment subject the satisfaction of B&R that such new levy/tax is applicable to this contract if payable by our Client.

51.00 MOBILIZATION ADVANCE :

No Mobilization Advance will be paid to Contractor.

52.00 SECURED ADVANCE:

No Secured Advance shall be paid to the Contractor.

53.00 TAXES AND DUTIES

The Contractor should be registered with GST authority, Contractor shall be exclusively responsible for payment of all Taxes, Royalties etc. (Except Goods and Services Tax) that may be levied from time to time according to the Laws & Regulation now in force & also hereafter to be imposed, increased or modified from time to time. Nothing will be payable extra by the company in respect of any duties/taxes to be imposed on procurement of materials for execution of works contract.

54.00 GST-TDS:

GST-TDS will be deducted by cash at source from Contractor's Invoice value before GST under GST Law w.e.f. 01.10.2018 as per Govt. Notification No. 50/2018-Central Tax dated 13.09.2018 for Taxable Services as per Act & Rules framed there under at such rates as maybe applicable from time to time.

55.00 CANCELLATION OF CONTRACT:

- (l) If the Contractor:
- (a) at any time makes default in proceeding with the works with due diligence and continues to do so after a notice in writing of 07 days from the Engineer-in-Charge. Or

- (b) Commits default in completing with any of the terms and conditions of the Contract and does not remedy it or take effective steps to remedy it within 07 days after a notice in writing is given to him in that behalf by the Engineer-in-Charge.
Or,
- (c) Fails to complete the Works or items of work with individual dates of completion, on or before the date(s) of completion, and does not complete them within the period specified in a notice given in writing in that behalf by the Engineer-in-Charge.
Or,
- (d) Shall offer or give or agree to give to any person in Company's service or to any other person on his behalf any gift of consideration of any kind as an inducement or reward for doing or for bearing to do or for having done or forborne to do any act in relation to the obtaining or execution of this or any other Contract for the Company.
Or,
- (e) Shall enter into a Contract with the Company in connection with which omission has been paid or agreed to be paid by him or to his knowledge, unless the particulars of any such commission and the terms of payment thereof have previously been disclosed in writing to the Accepting Authority/ Engineer-in-Charge.
Or,
- (f) Shall obtain a Contract with the Company as a result of ring tendering or other non-bonafied methods of competitive tendering
Or,
- (g) Being an individual, or if firm, any partner thereof, shall at any time be adjudged insolvent or have areceiving order or order for administration of his estate made against him or shall take any proceedings for liquidation or composition (other than a voluntary liquidation for the purpose of amalgamation or reconstruction under any Insolvency Act for the time being in force or make any conveyance or assignment of his effective or composition or arrangement for the benefit of his creditors or purport so to do, or if any application be made under any Insolvency Act for the time being in force for the sequestration of his estate or if a trust deed be executed by him for benefit of his creditors.
Or,
- (h) Being a Company, shall pass a resolution or the Court shall make an order the liquidation of his affairs, or a receiver or manager on behalf of the debenture holders shall be appointed or circumstances shall arise which entitle the Court or debenture holders to appoint a receiver or manager.
Or,
- (i) Shall suffer an execution being levied on his goods and allow it to be continued for a period of 21 days.
Or,
- (j) Assigns, transfers, sublets (engagement of labour on a piece-work basis or of labour with materials not to be incorporated in the work, shall not be deemed to be subletting) or attempts to assign, transfer or sublet the entire works or any portion thereof without the prior written approval of the Accepting Authority, the Accepting Authority may, without prejudice to any other right to remedy which shall have accrued or shall accrue thereafter to the Company by written notice cancel the Contract as a whole or only such items or work in default from the Contract.

(II) The Accepting Authority shall on such cancellation have powers to:

- (a) take possession of the Site and any materials constructional plant, implements, stores, etc., thereon and/or
- (b) carry out the incomplete work by any means at the risk and cost of the Contractor.

(III) Any excess expenditure incurred or to be incurred by the Company in completing the works or part of the works or the excess loss or damages suffered or may be suffered by the company as aforesaid after allowing such credit shall be recovered from any money due to the Contractor on any account, and if such money are not sufficient the Contractor shall be called upon in writing to pay the same within 30 days.

56.00 SAFETY AND SECURITY:

The Contractor shall ensure and arrange at his cost fire and the safety provisions, as per Indian standards

Institution, safety manual of the Employer, if any, and such provisions as are locally in force time to time for all labour, directly or indirectly employed in the works for performance of this contract. The contractor will indemnify the employer from any consequences arising due to contractor's failure in respect of safety provision. (The detailed terms & conditions related to Safety at Site is attached).

57.00 ACCIDENTS-STATUTORY REPORTING:

When any accident(s) occurs which causes loss of life or which causes any bodily injury by reason of which the person injured is prevented from working for a period of forty eight hours or more immediately following the accident, or which is of such in nature as may be prescribed by laws (Dangerous occurrences), the contractor shall give notice thereof to such authority in such form and within such time as may be prescribed by laws. The contractor shall indemnify the Employer from all accident cases.

58.00 URGENT WORKS:

If any urgent work (in respect whereof the decision of the Engineer-in-Charge shall be final and binding) becomes necessary and the Contractor is unable or unwilling at once to carry it out, the Engineer-in-Charge may be his own or other work people carry it out, as he may consider necessary. If the urgent work shall be such as the Contractor is liable under the Contract to carry out at his expense, all expenses incurred on it by the Company shall be recoverable from the Contractor and be adjusted or set off against any such payable to him.

59.00 SPECIFICATION AND INSPECTION:

(a) Entire work has to be carried out strictly as per the standards, Technical specifications, Scope of work, and drawings of B&R & Owner as applicable for this works.

(b) Works will be accepted only after the same is inspected and accepted by B&R & Owner.

60.00 SITE VISIT BY THE CONTRACTOR:

By submitting the bid, bidders shall be deemed to have inspected and examined the work site, its surroundings, locality, nature of the ground, the scope and nature of work for the completion of work, safety requirements, quality requirements, environmental requirements, statutory requirements and other requirement of B&R. Bidders will also be deemed to have obtained all information to the risks and contingencies, responsibilities and other circumstances which might influence/ affect on his bid and to have taken into account all conditions and difficulties that may be encountered during the progress of work. The rates quoted in the bid shall be deemed adequate to complete the works according to the agreement and to cover the entire responsibility involved in the execution, completion and maintenance of the work. Bidder shall further be deemed to have included all labour cost towards compliance to statutory rules and all other charges necessary for completion of the work. Work under the contract shall be executed as given in this tender document and as required at site whether specifically mentioned or not. The Contractor shall carry out and complete the work under the contract in every respect in conformity with the contract documents/ work order and as per direction and to the satisfaction of the Engineer-In-Charge.

61.00 REGISTRATION OF THE CONTRACT WITH STATUTORY AUTHORITIES:

Within 30 (thirty) days from the issue of LOI/WO whichever is earlier the Contractor shall register themselves and the Contractor at their own cost with all relevant Governmental Authorities and as may be required pursuant to Applicable Law, including without limitation, the Reserve Bank of India, Income Tax authorities and GST authorities. The Contract Price shall be deemed to include all costs towards the same. A copy of all documents related to all such registration shall be submitted to the Client/B&R for record.

62.00 SITE CLEANING:

The Contractor shall take care for cleaning the Site from time to time for easy access to the site and also from safety point of view. All such work shall be carried out by the Contractor at its own cost and risk.

The Site should be always kept cleaned up to the full satisfactions of the Engineer-in-Charge. Before handing over the entire facilities or a part thereof to the Owner & B&R the Contractor in addition to other formalities to be observed as detailed in the document shall clear the site to the full satisfaction of the Engineer-in-Charge and the Governmental Authority having jurisdiction over it.

63.00 GATE PASS FORMALITY:

Since the entire security system is controlled by Security Personal, all the labours/staffs should have proper identification cards along with individual police verification reports, Medical Fitness Certificate so that necessary gate passes can be arranged for them. All other safety & security measures of the plant should be strictly followed by the Contractor.

- 64.00 SPLITTING OF WORK:**
The right to reject any or all offer(s) or split up the total requirement and award the contract to one or to more than one bidder if considered necessary or to cancel the bid rests with B&R.
- 65.00 WATER & ELECTRICITY:**
Construction Water and Power shall be Arrange by Contractor at his own cost.
- 66.00 ACCOMMODATION & STAFF TRANSPORT ETC.**
The Agency shall arrange, within his Quoted Rates, accommodations for his all Workmen, Technicians & Supervisors. Also, the Agency within his Quoted Rates shall arrange their Transport to the site and back.
- 67.00 MATERIAL TRANSPORTATION:**
Transportation of Materials through Traylor/Truck from work shop / Yard to respective relocated sites etc. instruction by Engineer-in-charge shall be done by Sub-Contractor.
- 68.00 REJECTION OF MATERIALS**
All materials brought to the site for use in the work shall be as per the specification of relevant item of work. All materials brought to the site must be approved by the B&R/NR prior to use in the work. Rejected materials must be removed by the Sub-Contractor from the site within 24 hours of the issue of order to that effect. In case of non-compliance of such order, the Engineer-In-Charge shall have the authority to cause such removal at the cost and expense of the Sub-Contractor and the Sub-Contractor shall not be entitled to claim for any loss or damage of that account
- 69.00 SETTLEMENT OF EXTRA ITEM:**
The rate for any items of work if not covered by the Schedule of Quantities & Rates under the Contractors scope of work shall be fixed mutually. For such extra items, rates are to be derived from analysis of cost on inputs and direct market rate documents are to be provided by the contractor. In this regard decision of Engineer-in-Charge shall be final & binding the Contractor.
- 70.00 FORCEMAJEURE:**
Should there be war, whether declared or not, instruction restraint imposed by the Govt. of any authority, Act of legislature or other stoppage, delay or hindrances in the supply of fuel, explosion, accident, illegal strike, riot, Civil commotion, curfew, sabotage or other disorganization of labour or transport or any other inevitable or unforeseen event beyond control directly interfering in the work, which causes delay in execution of the work or should delays arise from any which have grounds for grant for additional time extension time shall be granted.
- 72.00 MEASURE TO PROTECT CLIENT'S / B&R'S PROPERTY:**
The contractor shall take all the possible measures to protect the properties of the Client / B&R at work site from any damages from his any workers & staff.
- 73.00 LIABILITY FOR DAMAGED EFFECTS OF IMPERFECTION AND RECTIFICATION THEREOF:**
If the Sub-Contractor or his workmen or employees shall in jure or destroy any part of the building in which they may be working or any building, road, fence etc. contiguous to the premises on which the work or any part of it is being executed, or if any damage shall happen to the work while in progress the Sub-Contractor shall upon receipt of a notice in writing in that behalf make the same good at his own expenses.
- If it shall appear the Engineer-in-Charge or his Representative at any time during construction or re-construction or prior to the expiration of the Defects Liability Period, that any work has been executed with unsound, imperfect, or unskilled workmanship or that any materials or articles provided by the Sub-Contractor for execution of the work are un sound or of a quality inferior to that contract for, or otherwise not in accordance with the Contract, or that any defect, shrink age or other faults have appeared in the work arising out of defective or improper materials or workmanship, the Sub-Contractor shall, upon receipt tonotice in writing in that be half from the Engineer-in-Charge forth with rectify or remove and reconstruct the work so specified in whole or part as the case may be and/or remove the materials or article so specified and provide other proper and suitable materials or articles at his own expense, notwithstanding that the same may have been in advertently passed, certified and paid for and in the event of his failing to do so within the period to be specified by the Engineer-In-Charge in his notice aforesaid, the Engineer-In-Charge may rectify or remove and re-execute the work and/or remove and replace with other materials or articles/complained of, as the case may be, by other means at the risk of the Sub-Contractor.
- 73.01** The Sub-Contractor shall provide, if necessary or if required on the site, all temporary access thereto and shall alter, adopt and maintain the same as required from time to time and shall take up and clear them away as and

when no longer required and as and when ordered by the Engineer-in-charge and make good all damages done to the site.

74.00 DEFECTS AFTER TAKING OVER:

In order that the Contractor could obtain a completion certificate he shall make good with all possible speed any defect arising from the defective workmanship by the Contractor or that may have been noted or developed, after the works or group of works have been taken over. The period allowed, for carrying out such work will be normally 1 (one) month. If any defect be not remedied within a reasonable time, the Company may proceed to do the work at Contractor's risk and expense and deduct from the final bill or any other dues of the Contractor's such amount as may be decided by the Company.

75.00 FORECLOSURE OF CONTRACT DUE TO ABANDONMENT OR REDUCTION IN SCOPE OF WORK

If at any time after acceptance of the tender or during the progress of work, the purpose or object for which the work is being done changes due to any supervening cause and as a result of which the work has to be abandoned or reduced in scope the Engineer-in-Charge shall give notice in writing to that effect to the contractor stating the decision as well as the cause for such decision and the contractor shall act accordingly in the matter. The contractor shall have no claim to any payment of compensation or otherwise whatsoever, on account of any profit or advantage which he might have derived from the execution of the works in full but which he did not derive in consequence of the foreclosure of the whole or part of the works.

The Contractor shall be paid at contract rates full amount for works executed at site and, in addition, a reasonable amount as certified by the Engineer-in-Charge for the items hereunder mentioned which could not be utilized on the work to the full extent in view of the foreclosure:

- i) Any expenditure incurred on preliminary site work, e.g. temporary access roads, temporary labour huts, staff quarters and site office; storage accommodation and water storage tanks.
- ii) Employer shall have option to take over Contractor's materials or any part thereof either brought to site or of which the Contractor is legally bound to accept delivery from suppliers (for incorporation in or incidental to the work) provided, however, Employer shall be bound to take over the materials or such portions thereof as the Contractor does not desire to retain. For materials taken over or to be taken over by employer, cost of such materials as detailed by Engineer-in-Charge shall be paid. The cost shall, however, take into account purchase price, cost of transportation and deterioration or damage which may have been caused to materials whilst in the custody of the Contractor.
- iii) Reasonable compensation for transfer of T and P from site to Contractor's permanent stores or to his other works, whichever is less. If T and P are not transported to either of the said places, no cost of transportation shall be payable.
- iv) Reasonable compensation for repatriation of Contractor's site staff and imported labour to the extent necessary.

The Contractor shall, if required by the Engineer-in-Charge, furnish to him, books of account, wage books, time sheets and other relevant documents and evidence as may be necessary to enable him to certify the reasonable amount payable under this condition.

The reasonable amount of items on (i), (ii) and (iv) above shall not be in excess of 2% of the cost of the work remaining incomplete on the date of closure, i.e. total stipulated cost of the work as per accepted tender less the cost of work actually executed under the contract and less the cost of Contractor's materials at site taken over by Employer as per item (ii) above. Provided always that against any payments due to the Contractor on this account or otherwise, the Engineer-in-Charge shall be entitled to recover or be credited with any outstanding balances due from the Contractor for advance paid in respect of any tool, plants and materials and any other sums which at the date of termination were recoverable by Employer from the Contractor under the terms of the contract.

In the event of action being taken under Clause 67 to reduce the scope of work, the contractor may furnish fresh Performance Guarantee on the same conditions, in the same manner and at the same rate for the balance tendered amount and initially valid up to the extended date of completion or stipulated date of completion if no extension has been granted plus 60 days beyond that. Wherever such a fresh Performance Guarantee is furnished by the contractor the Engineer-in-Charge may return the previous Performance Guarantee.

76.00 CARRYING OUT PART WORK AT RISK & COST OF CONTRACTOR:

If Contractor:

- i) at any time makes default during currency of work or does not execute any part of the work with the due diligence and continues to do so even after a notice in writing of 7 (Seven) working days in this respect from the Engineer-in-Charge; or
- ii) commits default in complying with any of the terms and conditions of the contract and does not remedy it or take effective steps to remedy it within 7 (Seven) working days even after a notice in writing is given to him in that behalf by the Engineer-in-Charge; or

Fails to complete the works or items of work with individual dates of completion, on or before the date(s) so determined, and does not complete them within the period specified in the notice given in writing in that behalf by the Engineer-in-Charge; or

- iii) The Engineer-in-Charge without invoking action may, without prejudice to any other right or remedy against the contractor which have either accrued or accrue thereafter to Government, by a notice in writing to take the part work / part incomplete work of any item(s) out of his hands and shall have powers to:

Take possession of the site and any materials, constructional plant, implements, stores, etc., thereon; and/or

Carry out the part work / part incomplete work of any item(s) by any means at the risk and cost of the contractor.

The Engineer-in-Charge shall determine the amount, if any, is recoverable from the contractor for completion of the part work/ part incomplete work of any item(s) taken out of his hands and execute at the risk and cost of the contractor, the liability of contractor on account of loss or damage suffered by B&R/NR Authority because of action under this clause shall not exceed 10% of the tendered value of the work.

In determining the amount, credit shall be given to the contractor with the value of work done in all respect in the same manner and at the same rate as if it had been carried out by the original contractor under the terms of his contract, the value of contractor's materials taken over and incorporated in the work and use of plant and machinery belonging to the contractor. The certificate of the Engineer-in-Charge as to the value of work done shall be final and conclusive against the contractor provided always that action under this clause shall only be taken after giving notice in writing to the contractor. Provided also that if the expenses incurred by the department are less than the amount payable to the contractor at his agreement rates, the difference shall not be payable to the contractor.

Any excess expenditure incurred or to be incurred by Employer (B&R/Owner) in completing the part work/ part incomplete work of any item(s) or the excess loss of damages suffered or may be suffered by Employer (B&R) as aforesaid after allowing such credit shall without prejudice to any other right or remedy available to Owner in law or per as agreement be recovered from any money due to the contractor on any account, and if such money is insufficient, the contractor shall be called upon in writing and shall be liable to pay the same within 30 days.

If the contractor fails to pay the required sum within the aforesaid period of 30 days, the Engineer-in-Charge shall have the right to sell any or all of the contractors' unused materials, constructional plant, implements, temporary building at site etc. and adjust the proceeds of sale thereof towards the dues recoverable from the contractor under the contract and if thereafter there remains any balance outstanding, it shall be recovered in accordance with the provisions of the contract.

In the event of above course being adopted by the Engineer-in-Charge, the contractor shall have no claim to compensation for any loss sustained by him by reason of his having purchased or procured any materials or entered into any engagements or made any advance on any account or with a view to the execution of the work or the performance of the contract.

77.00 SUB-CONTRACTOR'S LIABILITY & INSURANCE:

From commencement to completion of the works, the Sub-Contractor shall take full responsibility for the case thereof & for taking precautions to prevent loss or damage & to minimize loss or damage to the greatest extent possible and shall be liable for any damage or loss that may happen to the works or any part thereof and all Company's T&P if supplied by B&R from any cause whatsoever (save and except the Excepted Risks) and shall at his own cost repair and make good the same so that at completion, the works and all company's T&P shall be in

good order and condition and in conformity in every respect with requirements of the Contract and instructions of the Engineer-in-Charge.

78.00 THIRD PARTY INSURANCE:

- (i) Before commencing the execution of the works the Contractor, but without limiting his obligations and responsibilities under Clause hereof, shall insure against his liability for any material or physical damage, loss or injury which may occur to any property including that of the Employer, or to any person, including that of the Employee of the employer, by or arising out of the execution of the works or in the carrying out of the contract.
- (ii) Minimum Amount of Third Party Insurance:
- (iii) Provision to Indemnify Employer:
- (iv) The terms shall include a provision whereby, in the event of any claim in any respect of which the Contractor would be entitled to receive indemnity under the policy being brought or made against the Company, the insurer will indemnify the Company against such claims and any cost, charges and expenses in respect thereof.
- (v) Amount of Such insurance shall be decided by our Engineer-in-Charge, Whose decision in this regard shall be final & binding upon the Contractor

79.00 ARBITRATION:

B&R confidently feel that there shall not arise any disputes or differences during execution and completion of the order/contract by the Contractor(s).

However, in the event of any dispute arising between the Company and the Contractor (hereinafter referred individually as "the Party" and collectively as "the Parties"), concerning the interpretation of any terms and conditions of the Contract and / or contractual obligations/performance / liabilities / responsibilities of the Parties to the said Contract, the disputing Party shall refer the matter to the other Party for holding a mutual discussion for resolving the dispute. In case the parties fail to arrive to any settlement through mutual discussion, either of the parties may avail the following remedies:

RESOLUTION OF DISPUTE THROUGH CONCILIATION:-

Any party may refer the dispute for Conciliation under Rules of Conciliation and Arbitration under SCOPE Forum of Conciliation and Arbitration (SFCA), 2003 and amendments made thereto from time to time (hereinafter referred as "the Rules") by making application to the Secretariat of the SCOPE Forum.

The Party initiating conciliation shall send to the other party & written invitation to conciliate under the Rules, briefly identifying the subject matter of the dispute.

The settlement so rendered between the Parties in pursuance thereof shall be final and binding on the parties.

If the other party rejects the invitation, there will be no conciliation proceedings at all.

RESOLUTION OF DISPUTE THROUGH ARBITRATION:

In case the dispute is not settled by conciliation within 30 days of the initiation of conciliation or such further period as the parties shall agree in writing, the dispute shall be referred to and finally resolved by Arbitration, in accordance with the Rules of Arbitration of Scope Forum of Conciliation and Arbitration, 2003 and amendments made thereto from time to time.

The entire proceedings of Arbitration shall be governed under the Arbitration and Conciliation Act, 1996.

The venue of Arbitration shall be mutually decided by the parties.

In case the parties do not agree for resolution of dispute through Conciliation and Arbitration by the above-mentioned SCOPE Forum, the disputing Party shall opt for stipulated rules laid down under the Arbitration and conciliation Act, 1996.

The Contract and the Parties therein shall be governed under the jurisdiction of Kolkata High Court.

In the event of any dispute of difference relating to the interpretation and application of the provisions of the contracts and commercial agreements (except Income Tax, Customs, Excise Duty and also concerning Dept.) between company (B&R) and any other Public Sector Undertaking/Government Department/Bank/Port Trust etc., such dispute or difference shall be referred by either party for Arbitration to the sole Arbitrator in the Department of Public Enterprises to be nominated by the Secretary of the Government of India in-charge of the Department of

Public Enterprises. The Arbitration and Conciliation Act,1996 shall not be applicable to arbitration under this clause.

The award of the Arbitrator shall be binding upon the parties to the dispute, provided, however, any party aggrieved by such award may take a further reference for setting aside or revision of the award to the Law Secretary, Department of Legal Affairs, Ministry of Law & Justice, Government of India.

Upon such reference the dispute shall be decided by the Law Secretary or the Special Secretary/Additional Secretary, when so authorized by the Law Secretary, whose decision shall bind the Parties finally and conclusively. The parties to the dispute will share equally the cost of arbitration as intimated by the Arbitrator.

Subject to any amendment that may be carried out by the Government of India from time to time, the procedure to be followed in the arbitration shall be as mentioned above, which is as per O.M.No.4(1)/2011-DPE(PMA)GL dated 12.6.2013 of Department of Public Enterprises, Ministry of Heavy Industries and Public Enterprises, Govt. Of India or any modification issued in this regard.

80.00 **JURISDICTION:**

In regard to all disputes or claims arising out of this Contract of whatever nature, only the High Court at Kolkata shall alone have the exclusive jurisdiction.

BRIDGE AND ROOF CO. (INDIA) LTD.

(A GOVERNMENT OF INDIA ENTERPRISE)

Santragachi Station Development Work site,
1st Floor, New Station Building, Platform No. 6
Santragachi, PIN- 711 111, West Bengal

EXECUTION OF RCC ROAD ALONG WITH FOOTPATH, DRAINAGE AND MISCELLANEOUS FINISHING WORK ON SUB-CONTRACT BASIS IN CONNECTION WITH "CONSTRUCTION OF NEW ISLAND PLATFORM AND REFURBISHING OF EXISTING PLATFORMS INCLUDING PLATFORM SHADE AT SANTRAGACHI RAILWAY STATION REGARDING STATION DEVELOPMENT WORK FOR SOUTH EASTERN RAILWAY IN WEST BENGAL.

NOTICE INVITING TENDER (NIT) No.:B AND R/51110/TD/SC/RCC ROAD WORK/01 DTD. 13/06/2024

ANNEXURE – IV

SPECIAL CONDITION OF CONTRACT(SCC)

BRIDGE AND ROOF CO. (INDIA) LIMITED
SPECIAL CONDITIONS OF CONTRACT (SCC)

1.00 GENERAL:

- 1.1 Special Conditions of Contract (SCC) shall be read in conjunction with the General Conditions of Contract (GCC), specifications of work, drawings and other documents forming part of this contract wherever the context so requires.
- 1.2 Notwithstanding the sub-division of the documents into these separate parts and volumes, every part of each shall be deemed to be supplementary to and complementary of every other part and shall be read with and into the contract in so far as it may be practicable to do so.
- 1.3 Where any provision of the GCC is repugnant to or at variance with any provision of the SCC, then the provision of the SCC shall be deemed to override the provisions of the GCC and shall, to the extent of such repugnance or variations, prevail.
- 1.4 Wherever it is mentioned in the specifications that the contractor shall perform certain works or provide certain facilities, it is understood that the contractor shall do so at his own cost, being deemed to be part of the relevant item in the Schedule of Rates (SOR) whether expressly stated or not.
- 1.5 The design and workmanship shall satisfy the relevant Indian/ ASME/API/BS/OISD or any other Standards, the specifications contained herein and codes referred to. Where the specifications stipulate requirements in addition to these contained in the standard codes and specifications, these additional requirements shall also be satisfied.

2.00 DEFINITION OF TERMS:

The various terms appearing in the Tender Document shall have the following meaning unless they are repugnant to the context otherwise.

- a) Company : Bridge And Roof Co. (India) Limited (B AND R) having its registered office at "Kankaria Centre", 2/1, Russel Street, (5th Floor), Kolkata – 700071, inviting this Tender.
- b) Employer/Owner : South Eastern Railway under Ministry of Railways", Government of India (here-in-after called SER) and shall include their authorized representatives, successors and permitted assigns as well as their authorized officer / representatives.
- c) Client/Consultant : IRCON International Limited
- d) Tenderer/Bidder : The firm/party who shall tender quotation to the Company.
- e) Contractor/
Successful Bidder : The Tenderer whose quoted offer will be accepted, either in full or in part, by the Company.
- f) Work(s) : Jobs that are to be executed by the Contractor as awarded to him by the Company.
- g) LOI / Work-Order/Contract : The formal letter / notification issued to the Contractor awarding the work(s) in full or in part by the Company together with the applicable terms & conditions etc. as are finally & mutually agreed to between the Company and the Contractor.
- h) Site/Worksite : The premises where the work will be executed by the Contractor and shall include the lands, buildings, structures etc.
- i) Engineer-in-Charge : The Officer/Engineer nominated & authorized by the Company for the time being for the purpose of operating the Contract or any work covered there under.
- j) Accepting Authority : Chairman Cum Managing Director of the Company.

3.00 SCOPE OF WORK:

Scope of work to be executed under this tender shall include but not limited to the following works which is only indicative but not exhaustive. The Sub-contractor shall carry out and complete all related works so as to make the scheme complete in all respect of technical requirements and to deliver the desired output/performance.

Scope of Supply by Bidder

- a) All types of required manpower (i.e. Skilled, unskilled & semi-skilled labour etc.) will be totally arranged by the contractor for execution of work.
- b) All types of PPEs like safety shoes, safety net, safety glasses, safety belts, safety helmet, gum boots, hand gloves etc. will be arranged by contractor as per requirement.
- c) All necessary materials and Equipment, Machineries as required during execution of work at project site will be arranged by contractor as per instruction of Engineer-in-charge.
- d) BOCW Cess as per statutory rules.

4.00 DETAIL SCOPE OF WORK:

The work consist of a) Earthwork in Excavation & filling, b) Brick flat soiling, c) Form work d) Brick work Full & Half e) RCC & PCC work , f) Reinforcement work, g) Sand spreading work to be carried out in accordance with the drawings and Schedule of Quantities & Rates. It includes furnishing all materials, labour, equipment & Machineries and management necessary for the incidental to the construction and completion of the work. All work, during its progress and upon completion, shall conform to the lines, elevations and grades as shown on the drawings furnished by the Company. Should any detail essential for efficient completion of the work be omitted from the drawings and specifications it shall be the responsibility of the Contractor to inform the Company and to furnish and install such detail with Company's concurrence, so that upon completion of the proposed work the same will be acceptable and ready for use.

4.00 SPECIFICATIONS AND CODES

4.01 The execution of all works under this Tender shall conform to the specifications and codes of practice of Indian Railways as amended from time to time. The Owner reserves the right to reject or alter any part of the work executed by the Contractor, which in the judgment of the Owner does not comply with the requirement of the above specifications. The decision of the Owner shall be final and conclusive for all purposes.

4.01 "Indian Railway's Unified Standard Specifications -2010 Vol. I & II" shall govern the specifications of all items of USOR 2010 appearing in the tender schedule except for those items for which specifications have been given in special conditions related to site data & specifications, for such items, same (specifications in special condition) shall prevail. In case, specifications of any item are not covered in above, the relevant IRS/BIS/IRC code shall be applicable, in preference, as listed herein.

4.02 All material to be used in the works shall be in conformity with the requirement laid down in the "Indian Railway's Unified Standard Specifications -2010 Vol. I & II" or the relevant BIS Code/or any other relevant code applicable.

4.03 The decision of the Chief Engineer/Engineer-in-Charge of the project shall be final and binding regarding the interpretation of various provisions of the Codes and Specifications as well as the provisions/ clauses of the contract and no claim whatsoever shall be entertained on this account.

5.00 CHANGE IN SPECIFICATIONS:

Any minor change in SPECIFICATIONS, as found essential by OWNER, for coordinating the execution of WORK with other trades / third party / agency engaged by the OWNER, shall be accepted by the CONTRACTOR without any additional cost to the OWNER.

6.00 APPROVED RAILWAY DRAWINGS

6.01 The work shall be carried out as per approved railway drawings. The copies of the approved plan and additional information as required by the tenderers may be obtained (subject to availability) from the office.

6.02 The Chief Engineer/Engineer-in-Charge shall have full power to make any alteration in the drawings and to give such further instructions and directions as may appear to him necessary or proper for the guidance of contractor and for the efficient execution, completion and maintenance of the work. The contractor should plan the execution of various works in close co-ordination with the Engineer-in-Charge or his authorized representative.

7.00 **DEFECTS LIABILITY PERIOD:**

The Contractor shall guarantee and maintain the works for a period of **365 days or one monsoon whichever is later**. The Contractor shall be responsible to make good and remedy at his own expenses within such period as may be stipulated by the Engineer-in-Charge, any defect which may develop or may be noticed before the expiry of Defect Liability Period/ Maintenance period.

8.00 **TAXES & DUTIES:**

The contractor shall be exclusively responsible for payment of all Taxes & duties (Except Goods and Services Tax) that may be levied from time to time according to the Laws & Regulation now in force & also hereafter to be imposed, increased or modified from time to time. Nothing will be payable extra by the company in respect of any duties/Taxes to be imposed on procurement of materials for execution of works contract.

9.00 **GOODS AND SERVICE TAX (GST):**

Without prejudice to stipulation in General Conditions of Contract, the quoted price shall be exclusive of Goods and Services Tax. The GST as legally leviable & payable by the bidder under the provisions of applicable law/act shall be paid extra by B&R as per Bidder's GST Tax Invoice. Bidder shall quote their rates after considering the input tax credit on their input materials and services.

In this works, as transfer of property of goods is involved in connection with immovable property, GST under supply of services is applicable. The bidder shall get registered with the GST authorities and the registration certificate shall be submitted along the bid documents (techno commercial). Bid without GST number shall be cancelled.

The GST (i.e. SGST, CGST or IGST) amount shall be shown separately in invoice and also submit proper Tax Invoice as per section 31 of CGST Act, and Rule 46 of CGST Rules, 2017 to get Input Tax Credit by B&R. Declaration as per format given in Annexure-I to be submitted along with bid Documents.

Bidder shall raise their tax invoice in regular interval as per contract condition and uploaded their supply invoice in GSTN Portal through GSTR-1 return within 11th and GSTR-3B within 20th of next month & Mismatch in return of B&R due to any reason attributable to bidder, the same shall be recovered from Bidder's bill.

In case, B&R's Input Tax Credit (ITC) is rejected on account of wrong levy of tax i.e. payment of Integrated Tax in place of Central Tax+ State/Union Territory Tax or vice versa, the contractor is liable to make good the loss suffered by B&R by issuance of suitable credit note to B&R. In case, contractor does not issue credit note to B&R, B&R would be constrained to recover the amount including interest payable along with Statutory levy, if any, payable on such recovery. Bidder shall specify the nature of GST applicable (i.e. IGST OR CGST & SGST) Bidder having registration in other **state (except West Bengal)** shall raise their Tax Invoice by charging IGST only.

B&R shall reimburse GST levied as per invoice issued by the Contractor as prescribed under section 46 of the CGST Rules 2017 and respective states Act and Rules.

To enable B&R to avail ITC, the contractor/supplier shall furnish/submit any and all certificates, documents and declarations as are required by B&R to avail of the ITC with respect to GST reimbursed by B&R on supply of Goods/services to B&R.

The HSN/SAC Code under which the goods/service will fall should be clearly mentioned along with the Rate at the time of submission of invoice for releasing payment.

In case, B&R is not able to take Input Tax Credit due to any noncompliance/default/negligence of the seller, the same shall be recovered from the pending bills/dues (including any security available with B&R).

Any benefit by way of reduction in rate of tax or increase in input tax credit arising due to introduction of GST shall be passed on to B&R through reduction in supply value by way of commensurate reduction in Bill value. The Contractor shall ensure that all the required documents as per the GST regulations are furnished to B&R with their invoices failing which B&R shall not make any reimbursement of such GST."

Note:

Goods & Services Tax (GST) as applicable shall be payable extra. The vendor will have to raise invoice for the applicable GST amount as per approved format for claiming the GST paid. Payment of GST is subject to reflection of the party's invoice in GSTR 2A /anx-2 (GST new return) of B&R.

10.00 GST-TDS:

As per section 51 of CGST Act 2017, B&R shall deduct at source @ 1% CGST & @ 1% SGST for intra state transaction and @2% IGST in the case of interstate transaction from the payment made or credited to the supplier of taxable goods and/or services, provided if the contract value is more than Rs. 2,50,000/-. This provision is applicable from the date to be notified by the Government. However, no deduction shall be made if the location of the supplier & the place of supply is in a State or Union Territory, which is different from the recipients registration State.

11.00 OTHER TAXES & DUTIES:

Any other charges (except GST) if any, as applicable, viz. Royalty, Stamp Duty, other charges / levies etc. prevailing / applicable on the date of opening of Technical Bids and any variations thereof during the tenure of the contract are in the scope of Bidder. B&R shall have the right to deduct all other charges as mentioned above from the Bidder's Bill(s)/any other due payment. In case B&R is forced to pay any such for the above, B&R shall have the right to recover the same from the Bidder either from Running Bills or otherwise as deemed fit.

12.00 NEW LEVIES/TAXES :

In case Government imposes any new levy/tax after award of the work during the tenure of the contract, B&R shall reimburse the same at actual on submission of documentary proof of payment subject the satisfaction of B&R that such new levy/tax is applicable to this contract if payable by our Client.

13.00 INCOME TAX:

Income Tax as applicable on works contract is included in the contract price. Income Tax shall be deducted from the contractor's bills as per the provisions of Income Tax Act.

14.00 PROVIDENT FUND:

The Contractor undertakes to discharge his responsibility under the employees provident fund scheme 1995 as an immediate employer, for employees engaged or employed by him for execution of contracted work, or as the next immediate employer in case he has assigned the contract or it has entered into a contract agreements for the said works.

The Contractor undertakes that all employees, either employed by him, or by his Contractor, or permitted assigns, would be covered under the above scheme from the date of commencement of work. The Contractor further undertakes to pay employee's contribution as well as employer's contribution at appropriate rate to the office of the regional provident fund commissioner within the stipulated time period for the same.

The Contractor acknowledges the right of the company to recover, deduct or claim any amount which the company is required to pay.

The establishment of the Contractor and its Contractors shall be duly registered under the Employees Provident Fund and Miscellaneous Provisions Act, 1952 and the Employees' State Insurance Act, 1948 and the Contractor shall duly and timely pay and ensure payment by its Contractors of contributions and its/their employees to the Authorities prescribed under the said Acts and any schemes framed thereunder in respect of all labour employed by it for the execution of the contract. Copies of challans/receipt of such payments along with the list showing persons employed together with emoluments paid for the purpose of provident fund deductions shall be submitted to B&R before the end of every calendar months. In case the relevant provident fund Authority's receipt/challans referred to above are not furnished, B&R shall deduct 5% (five percent) of the payable amount from the Running Bill and retain the deducted amount as a security for the contribution to provident fund. Such retained amounts shall be released to the Contractor only on production of challan/receipts of the relevant provident fund Authority for the period covered by the related deduction.

15.00 DIRECT TAX:

B&R shall not be liable towards Income Tax of whatever nature including variations thereof arising out of this contract as well as tax liability of the bidder and their personnel. Deduction of tax at source at the prevailing rates shall be effected by B&R before release of payment as a statutory obligation, unless exemption certificate is produced by the bidder. TDS certificate will be issued by B&R as per the provisions of Income Tax Act.

16.00 BOCW CESS:

Quoted Price shall be inclusive of BOCW Cess.

In Order to government welfare and working conditions of labourers engaged in construction activities, the Building and other Construction Workers' (Regulation of Employment and Conditions of Service Act, 1996, hereinafter referred to as the "RE & CS") came into force. The RE&CS Act is applicable in respect of building and other construction work. Wherever applicable, the Contractor shall strictly comply with the provisions pertaining to RE&CS Act. The Contractor must be registered with the concerned authorities under the RE&CS Act, or in case of non-registration the Contractor should obtain registration within one month of the award of the contract.

Cess as per the prevailing rate @ 1% shall be deducted at source from bills of the Contractor by the Engineer-in-Charge of the contract and remitted to the "Secretary, Building and other Construction Workers Welfare Board" of the concerned State. The Contractor shall be responsible to submit final assessment return of the cess amount to the assessing officer after adjusting the cess deducted at source.

Bidder shall raise their tax invoices on regular intervals as per contract conditions and upload their supply invoice in GSTN portal through GSTR-1 return within due date (presently 11") of next month. GST amount shall be paid to contractors after submission of GSTR-1 snapshot. If the ITC is not availed by B&R due to any reasons attributable to bidder (i.e. Mismatch in GSTR return, non-submission of GSTR-3B in time), the entire GST amount along with applicable interest shall be recovered from Bidder's bill.

17.00 QUANTITY VARIATION:

The Quantities indicated in SOQR are approximate and those may vary upward and downward to any extent within the quoted rate of the bidder and such variation over contract quantities shall not be liable for any additional claim. However, the total Contract Price may vary up to $\pm 25\%$ due to increase or decrease in the executed Quantities.

18.00 PRICE VARIANCE / ESCALATION:

Not applicable

19.00 LABOURCESS:

1 (One) % Labourcess to be deducted from contractor's Running Bill.

20.00 WORKMEN'S ACCOMMODATION:

Contractor shall arrange Workmen Accommodation at the labour hutment outside the Project Premises & their staff worker transportation at his own cost.

21.00 ENGINEER'S DECISION IN RESPECT OF LABOUR DEPLOYMENT:

Contractors shall arrange necessary labours as will be required to execute the works within the programmed schedule. In case this is felt by the Engineer-in-charge that the labours as deployed by the Contractors in works is not adequate, the Contractors shall be bound to increase the labour strength as per the instruction of the Engineer-in-charge without any extra cost to B&R for such increase of labour.

22.00 CONTRACTOR WILL FOLLOW STATUTORY RULES:

The Contractor shall strictly follow the statutory rules of Central/State Government and fulfill all the statutory obligations as stipulated in contract labour Regulation and Abolition Act. 1970, including all other acts as mentioned in relevant clauses of contract.

23.00 MEASURE TO PROTECT OWNER'S/VENDEE's & B&R'S PROPERTY:

The contractor shall take all the possible measures to protect the properties of the owner / B&R at work site from any damages from his any workers & staff.

24.00 CONTRACTOR'S RISK FOR LOSS OR DAMAGE :

All risk on account of railway or road carriage or Electrocutation or genital accident including loss or damage of vehicles, materials or labour, if any, will have to be borne by the Contractor without any extra claim towards B&R.

25.00 TERMINAL BENEFIT:

The quoted rates are inclusive of terminal benefits, which will be paid to the workers by the Contractors, as per statutory provision.

26.00 RATE REVISION:

Rates quoted by the contractor will remain firm till completion of the work. Claim for revision of rates on any ground whatsoever will not be admissible during the entire period of work.

27.00 WATER & ELECTRICITY:

Construction Water and Power shall be Arrange by Contractor.

28.00 PROCUREMENT OF CEMENT & REINFORCEMENT STEEL:

All Cement & reinforcement steel shall be procured as per specifications. Independent tests shall be conducted, wherever required, to ensure that the materials procured confirm to the specifications.

29.00 REINFORCEMENT STEEL:

The reinforcement steels for railway projects/contracts is to be procured from IRCON approved vendor SAIL/RINL/TISCON/JINDAL/ELECTRO STEEL/SRMB only or their authorized dealers/authorized stock yard which should confirm to latest relevant BIS specifications. In case of RDSO approved firms, contractor has to submit proof of approved firm.

30.00 CEMENT:

The Cement for railway projects/contracts is to be procured from IRCON approved vendor BIRLA/ULTRATECH/ACC/AMBUJA/JK CEMENT/LAFARGE(NUVOCO) only or their authorized dealers/authorized stock yard which should confirm to latest relevant BIS specifications. In case of RDSO approved firms, contractor has to submit proof of approved firm.

31.00 MATERIAL

All sorts of construction materials such as Stone Chips, Sand, Bricks, including R/F steel, cement, Structural Steel etc required for the work will be arranged by the contractor. Sample of materials like stone chips, sand, etc. must be got approved from Engineer before bringing the bulk materials at site.

If total purchasing cost of such material by B&R plus 10% towards service charge over such total cost.

32.00 CONSUMABLES:

The Contractor shall arrange at his own cost all consumable required for execution of his works.

33.00 SAFETY HELMET, SAFETY BELT & SAFETY SHOES:

The Contractor shall arrange all safety measuring protections like safety helmet, safety belt, safety shoes etc. required for execution of work.

34.00 DEPLOYMENT OF UN-SKILLED LABOUR:

Unskilled workers for executing the job are to be engaged from local land losers of the project duly certified and identified by the competent authority.

35.00 SUB - CONTRACT:

The Contractor shall not sublet any portion of the contract without the prior written approval of the Accepting Authority.

- 36.00 **TIE CLAUSE:**
In case of Tie between two or more bidders at L – I position, all the L – I bidders shall be asked to submit discount over previous quoted rate in a sealed envelope. The same price bids shall be opened in presence of the intending bidders & the bidder offering maximum discount shall be considered as the L1 bidder.
- 37.00 **SPLITTING OF WORK :**
The right to reject any or all offer(s) or split up the total requirement and award the contract to one or to more than one bidder if considered necessary or to cancel the bid rests with B&R.
- 38.00 **RETENTION MONEY :**
a) Retention Money shall be recovered from on account / final bills of the contractor @ 10% of gross value of each bill after adjusting EMD amount till the amount so recovered including EMD amount adds up to 5% of the contract value of the work. No interest shall be payable to the contractor on the amount retained in cash towards retention Money.

b) Retention Money will be deducted only from the running bills of the contract and no other mode of collecting Retention Money in the form of instruments like BG, FD etc. shall be accepted.

c) The Retention Money shall be released without any interest to the Contractor after preparation of final bill and acceptance of the same by the Contractor and after the expiry of the defect liability period specified in the Contract, reckoned from the date on which the Certificate of Completion comprising the whole of works has been issued. The retention money shall be released after all failures, defects, imperfections, shrinkages and faults have been rectified by the Contractor to the satisfaction of the Project Consultant, Engineer & Client and Defect Liability certificate is issued by the Employer and after passing the final bill based on "No claim certificate".

Retention Money shall be forfeited whenever the contract is rescinded.
- 39.00 **FORFEIT OF RETENTION MONEY:**
In case of giving up the work by the contractor without completing the job, the Retention Money retained and / or any other payment due to the contractor will be forfeited and B&R will claim additional amount from the contractor for any damage arising out of such act of contractor for which the contractor shall remain liable for payment.
- 40.00 **PERFORMANCE BANK GUARANTEE**
The successful bidder shall submit a Performance Bank Guarantee in the form of irrevocable bank guarantee from any Scheduled Bank for an amount of 5% (Five percent) of the Contract value. The value of PG to be submitted by the Contractor will not change for variation upto 25% (either increase or decrease). In case during the course of execution, value of Contract increases by more than 25% of the original contract value, an additional Performance guarantee amounting to 5% (five Percent) for the excess value over the original contract value should be deposited by the Contractor.
PBG shall be submitted by the successful bidder within 15 days from the date of issuance of letter of Intent. This guarantee shall be initially valid up to the stipulated date of Defect Liability Period (DLP) plus 60 days beyond that. In Case, the time of completion of work gets extended, the Contractor shall get the validity of PBG extended to cover such extended time for completion of work plus 60 days beyond Defect Liability Period.
No payment under the contract shall be made to the Contractor before receipt of performance security. Failure of the successful tenderer to furnish the required performance security shall be a ground for the annulment of the award of the Contract and forfeiture of the Earnest Money Deposit.
- 41.00 **RELEASE OF PBG**
The Performance Bank Guarantee shall be returned to the Contractor after completion of defect liability period (DLP) and subject to the issue of Completion Certificate.
- 42.00 **TERMS OF PAYMENT:**
Measurements of Contractor's work for the purpose of record and payment will be made on the basis of joint measurement against actual quantum of work executed & certified by B&R through monthly R/A bills as follows:

(a) 95% of Monthly running account bill shall be paid duly certified by the B&R as well as Consultant & Client and may be released after necessary deduction and getting corresponding payments from our Client.

(b) Balance 5% (Retention money) will be payable without any interest after completion of work in all respect alongwith final bill.

(c) Final Bill will be made within 2 (two) months on submission of the same to the Engineer-in-charge subject to the acceptance of Engineer-in-charge after completion of Defect Liability Period (i.e. 12 months from the date of completion of work).

All deductions towards Income Tax shall be effected from each and every R/A bill including final bill as per statute and as applicable in the place of work

43.00 COMPENSATION FOR DELAY/ LIQUIDATED DAMAGES:

The extension of time for completion of the work shall be governed by Clause 17-A & 17-B of the General Condition of Contract (GCC) -2014 of SE Railway amended upto the date of issue of NIT, and the contractor shall be responsible for requesting such extension in terms thereof. B&R/IRCON may, if satisfied that the works can be completed by the contractor within reasonable short time thereafter, allow the contractor for further extension of time as the Engineer may decide. On such extension B&R/IRCON will be entitled without prejudice to any other right and remedy available on that behalf, to recover from the contractor as agreed damages and not by way of penalty a sum equivalent to ½ of 1% of the contract value of the works for each week or part of the week.

B&R shall deduct the amount of such compensation from any money due or which may become due to the contractor and/or recover such compensation from the bank guarantees / earnest money / retention money of the contractor. To be entitled to impose such compensation, B&R will not be required to prove that he has incurred such amount as actual damage.

44.00 INSURANCE

Contractor shall at his own expense carry and maintain insurance with reputed insurance companies to the satisfaction of the Owner as follows

Employees State Insurance Act:

The contractor agrees to and does hereby accept full and exclusive liability for compliance with all obligations imposed by the Employees State Insurance Act., 1948, and the contractor further agrees to defend, indemnify and hold Owner harmless from any liability of penalty which may be imposed by the Central, State or Local authority by the reason of any asserted violation by contractor or Sub-contractor of the Employee's State Insurance Act, 1948 and also from all claims, suits or proceeding that may be brought against the Owner arising under, growing out of or by reasons of the work provided for by this contract whether brought by employees of the contractor, by third parties or by Central or State Government authority or any political sub-division thereof.

The contractor agrees to fill in with the Employees State Insurance Corporation, the Declaration Forms and all forms which may be required in respect of the contractor's or sub-contractor's employees, whose aggregate remuneration is Rs. 560.00 per month or less and who are employed in the work provided for or those covered by ESI from time to time under the Agreement. The contractor shall deduct and secure the agreement of the sub-contractor to deduct the employee's contribution as per the first schedule of the Employee's State Insurance Act from wages and affix the employee's contribution cards at wages payments intervals. The contractor shall remit and secure the agreement of the sub-contractor to remit to the State Bank of India, Employees State Insurance Corporation Account, the employee's contribution as required by the Act. The contractor agrees to maintain all cards and records as required under the Act in respect of employees and payments and the contractor shall secure the agreement of the sub-contractor to maintain such records. Any expenses incurred for the contributions, making contributions or maintaining records shall be to the contractor's or sub-contractor's account.

The Owner shall retain such sum as may be necessary from the total contract value until the contractor shall furnish satisfactory proof that all contribution as required by the Employees State Insurance Act, 1984, have been paid. This will be pending on the contractor when the Employees State Insurance Act is extended to the place of work.

Workmen Compensation and Employees Liability Insurance:

Insurance shall be affected for all the contractor's employees engaged in the performance of this contract. If any of the work is subject, the contractor shall require the sub-contractor to provide workmen's compensation and employer's liability insurance for the latter's employees if such employees are not covered under the contractor insurance.

Any other insurance required under Law or Regulations or by Owner:

Contractor shall also carry and maintain any and all other insurance, which he may require under any law or regulation from time to time. He shall also carry and maintain any other insurance, which may be required by the Owner.

Accident or Injury to workmen:

The owner shall not be liable for or in respect of any damages or compensation payable at law in respect or in consequence of any accident or injury to any workman or other person in the Employment of the contractor or any sub-contractor save and except and accident or injury resulting from any act or default of the Owner, his agents or servants and the contractor shall indemnify and keep indemnified the Owner against all such damages and compensation (save and except as aforesaid) and against all claims, demands, proceeding, costs, charges and expenses, whatsoever in respect or in relation thereto.

Transit Insurance:

In respect of all items to be transported by the Contractor to the site of work, the cost of transit insurance should be borne by the contractor and the quoted price shall be inclusive of this cost.

45.00 TESTING & MATERIAL TEST CERTIFICATE:

The contractor shall be liable for Testing of his works/materials as per specification and/or as per instruction of B&R/Client/Consultant without any additional charges for the same. B&R/B&R's may inspect the materials during Fabrication or after Fabrication at Contractor's workshop before delivery at site.

Material test certificates (MTC) of all materials from the approved laboratory of B&R/Client/Consultant will be required to be positively submitted alongwith the materials, brought by the contractor for his work. Third party inspection will be conducted if required. Contractor's quoted rates shall include all such cost as mentioned above.

46.00 COMPLIANCE OF SAFETY RULES :

The contractor should take all possible measures to avoid accidents to their labours and shall adopt all safety measures as will be directed by B AND R's Engineer-in-charge.

Contractor will remain liable for non-compliance of any shorts of safety measure instructed by Engineer from time to time during execution of the work. Non-compliance of safety measure as would be instructed by the Engineer, may lead to imposition of fine on the Contractor as per details given below and the Engineer shall be the sole Authority to decide the Amount of fine that will be imposed on him and the said amount of fine will be recovered from contractor's Running Account Bill and/or any other payment due to the contractor.

- i) Not wearing safety helmet, hand gloves and safety shoe---Fine will be Rs. 100 /- per workman.
- ii) Not wearing safety belt above 2.5 m. height ----- Fine will be Rs. 400 /- per workmen.
- iii) Grinding or gas cutting without goggles ----- Fine will be Rs. 100 /- per workmen
- iv) Gas cutting without taking proper precaution ---- Fine will be Rs. 200 /- per case.
- v) Welding without taking proper precaution ---- Fine will be Rs. 200 /- per case.
- vi) Not using safety net at height ----- Fine will be Rs. 800 /- per case.

KEY TECHNICAL PERSONNEL TO BE DEPLOYED FOR THE WORK

[Requirement of Principal Technical Representative(s) and recovery Rate]

Sl. No.	Minimum Qualification Discipline of Technical Representative	Qualification	Minimum Experience	Min. Number to be deployed	Rate at which recovery shall be made from the Contractor in the event of not fulfilling minimum number as mentioned	
					Figures (Rs.)	Words
1.	Site Engineer	Degree/ Diplomain Civil Engineering	5 years	1	25,000/-	Twenty Five Thousand
2.	Site Supervisor	H.S. or equivalent in any grade	6 years	1	20,000/-	Twenty Thousand

NOTE: The above mentioned technical personnel are required to be deputed at site within 30 days from issue of LOI

TOOLS , PLANTS and EQUIPMENTS TO BE DEPLOYED FOR THE WORK

Sl. No.	Name of Equipments	Minimum Nos. to be deployed by the successful bidder
1.	Concrete Mixer Machine	1 No.
2.	Excavator cum Backhoe Loader	1 No.
3.	Tractor with Trolley	1 No.
4.	Concrete Vibrator	1 No.
5.	Jack Hammer / Concrete breaker	1 No.
6.	DG Set	1 No.
7.	Vibro Roller	1 No.
8.	Earth compactor	1 No.
9.	Bar Cutting & Bending machine	1 No.

BRIDGE AND ROOF COMPANY (INDIA) LIMITED

CIN No.: U27310WB1920GOI003601

Santragachi Station Development Work site,
1st Floor, New Station Building, Platform No. 6
Santragachi, PIN- 711 111, West Bengal

NOTICE INVITING TENDER (NIT) No.:B AND R/51110/TD/SC/RCC ROAD WORK/01 DTD. 13/06/2024

EXECUTION OF RCC ROAD ALONG WITH FOOTPATH, DRAINAGE AND MISCELLANEOUS FINISHING WORK ON SUB-CONTRACT BASIS IN CONNECTION WITH "CONSTRUCTION OF NEW ISLAND PLATFORM AND REFURBISHING OF EXISTING PLATFORMS INCLUDING PLATFORM SHADE AT SANTRAGACHI RAILWAY STATION REGARDING STATION DEVELOPMENT WORK FOR SOUTH EASTERN RAILWAY IN WEST BENGAL

FORMATS

FORM OF BANK GUARANTEE IN LIEU OF SECURITY CUM PERFORMANCE
(To be executed on Non-Judicial Stamp Paper of Appropriate Value)

1. In consideration of the BRIDGE AND ROOF Co. (I) Ltd. (hereinafter called "The Employer") having offered to accept the terms and conditions of the proposed agreement between Employer and _____ (hereinafter called "the said Contractor(s)") for the work _____ (hereinafter called "the said agreement") having agreed to production of a irrevocable Bank Guarantee for Rs. _____ (Rupees _____ only) as a security/guarantee from the Contractor(s) for compliance of his obligations in accordance with the terms and condition in the said agreement.

We, _____ (hereinafter referred as "the Bank") hereby undertake to
(indicate the name of the Bank)
pay to the Employer an amount not exceeding Rs. _____ (Rupees
_____ only) on demand by the Employer.

2. We, _____ do hereby undertake to pay the amounts due and
(indicate the name of the Bank)
payable under this guarantee without any demure, merely on a demand from the Employer stating that the amount claimed is required to meet the recoveries due or likely to be due from the said Contractor(s). Any such demand made on the bank shall be conclusive as regards the amount due and payable by the bank under this Guarantee. However, our liability under this guarantee shall be restricted to an amount not exceeding Rs. _____ (Rupees
_____ only).

3. We, the said bank further undertake to pay the Employer unconditionally any money so demanded notwithstanding any dispute or disputes raised by the Contractor(s) in any suit or proceeding pending before any court or Tribunal or Arbitration or before any other authority relating thereto, our liability under this present being absolute and unequivocal.

The payment under this Guarantee so made by us under this bond shall be a valid discharge of our liability for payment there under and the Contractor(s) shall have no claim against us for making such payment.

4. We, _____ further agree that the guarantee herein contained shall
(indicate the name of the Bank)
remain in full force and effect during the period that would be taken for the performance of the said agreement and that it shall continue to be enforceable till all the dues of the Employer under or by virtue of the said agreement have been fully paid and its claims satisfied or discharged or till Engineer -in-Charge on behalf of the Employer certified that the terms and conditions of the said agreement have been fully and properly carried out by the said Contractor(s) and accordingly discharges this guarantee.

5. We, _____ further agree with the Employer that the Employer shall
(indicate the name of the Bank)
have the fullest liberty without our consent and without affecting in any manner our obligation hereunder to vary any of the terms and conditions of the said agreement or to extend time of performance by the said Contractor(s) from time to time or to postpone for any time or from time to time any of the powers exercisable by the Employer against the said Contractor(s) and to forbear or enforce any of the terms and conditions relating to the said agreement and we shall not be relieved from our liability by reason of any such variation, or extension being granted to the said Contractor(s) or for any forbearance, act of omission on the part of the Employer or any indulgence by the Employer to the said Contractor(s) or by any such matter or thing whatsoever which under the law relating to sureties would, but for this

provision, have effect of so relieving us.

This guarantee will not be discharged due to the change in the constitution of the Bank or the Contractor(s).

6. It shall not be necessary for the Company to proceed against the contractor before proceeding against the Guarantor bank and the Guarantee herein contained shall be enforceable against them notwithstanding any security, which the Company may have obtained or obtain from the contractor shall at the time when proceedings are taken against the guarantor hereunder be outstanding or unrealized.
7. The guarantor hereby declare that it has power to execute this guarantee and the executants has shall powers to do so on its behalf under the proper authority granted to him/them by the guarantor.
8. We, _____lastly undertake not to revoke this guarantee except with the
(indicate the name of the Bank)
previous consent of the Employer in writing.
9. This guarantee shall be valid upto _____ unless extended on demand by the Employer. Notwithstanding anything mentioned above, our liability against this guarantee is restricted to Rs. _____ (Rupees _____ only) and unless a claim in writing is lodged with us within six months of the date of expiry or the extended date of expiry of this guarantee all our liabilities under this guarantee shall stand discharged.

Dated the _____ day of _____ for _____(indicate the name of the Bank).

PURCHASE PREFERENCE TO MAKE IN INDIA

In line with Public Procurement (Preference to Make in India), Order 2017 dated 15.06.2017, 28.05.2018, 04.06.2020 and subsequent orders issued by the respective Nodal Ministry, Govt. of India by way of providing purchase preference, B AND R has implemented "Purchase Preference Policy". The "Purchase Preference" is applicable for the "Local Supplier" for the items / services covered in the tender subject to the following terms and conditions :

B AND R reserves right to consider Local supplier (i.e whose offered product or service meets the minimum local content of tender) in case, emerged L1 bidder is Non Local supplier and quoted prices of Local suppliers are in the bracket of L1 + 20% and if they agree to match with L1 prices as per the "Public Procurement (Preference to Make in India) order 2017 of GOI, Dept of DIPP"

1. DEFINITIONS:

'Local content' means the amount of value added in India which shall, unless otherwise prescribed by the Nodal Ministry, be the total value of the item procured (excluding net domestic indirect taxes) minus the value of imported content in the item (including all customs duties) as a proportion of the total value, in percent.

'Class-I local supplier' means a supplier or service provider, whose goods, services or works offered for procurement, has local content equal to or more than 50%, as defined under said Order

'Class-II local supplier' means a supplier or service provider, whose goods, services or works offered for procurement, has local content more than 20% but less than 50%, as defined under this Order.

'Non-Local supplier' means a supplier or service provider, whose goods, services or works offered for procurement, has local content less than or equal to 20%, as defined under this Order.

'L 1 ' means the lowest tender or lowest bid or the lowest quotation received in a tender, bidding process or other procurement solicitation as adjudged in the evaluation process as per the tender or other procurement solicitation

'Margin of purchase preference' means the maximum extent to which the price quoted by a "(Class-I local supplier)" may be above the L 1 price for the purpose of purchase preference.

'Procuring entity' means a Ministry or department or attached or subordinate office of, or autonomous body controlled by, the Government of India and includes Government companies as defined in the Companies Act.

'Works' means all works as per Rule 130 of GFR- 2017, and will also include turnkey works '.

2. ELIGIBILITY OF 'CLASS-I LOCAL SUPPLIER' / 'CLASS-II LOCAL SUPPLIER'/ 'NON-LOCAL SUPPLIERS' FOR DIFFERENT TYPES OF PROCUREMENT

(a) In procurement of all goods, services or works in respect of which the Nodal Ministry / Department has communicated that there is sufficient local capacity and local competition, only 'Class-I local supplier', as defined under the Order, shall be eligible to bid irrespective of purchase value.

(b) In procurement of all goods, services or works, not covered by 2(a) above, and with estimated value of purchases less than Rs.200 Crore, in accordance with Rule 161(iv) of GFR, 2017, Global Tender Enquiry shall not be issued except with the approval of competent authority as designated by Department of Expenditure. Only 'Class-I local supplier' and 'Class-II local supplier', as defined under the Order, shall be eligible to bid in procurements undertaken by procuring entities, except when Global Tender Enquiry has been issued. In Global Tender Enquiries, 'Non-local suppliers' shall also be eligible to bid along with 'Class-I local suppliers' and 'Class-II local suppliers'.

(c) For the purpose of this Order, works includes Engineering, Procurement and Construction (EPC) contracts and services include System Integrator (SI) contracts.

3A. PURCHASE PREFERENCE :

(a) Subject to the provisions of this Order and to any specific instructions issued by the Nodal Ministry or in pursuance of this Order, purchase preference shall be given to 'Class-I local supplier' in procurements undertaken by procuring entities in the manner specified here under.

(b) In the procurements of goods or works, which are covered by para 2(b) above and which are divisible in

nature, the 'Class-I local supplier' shall get purchase preference over 'Class-II local supplier' as well as 'Non-local supplier', as per following procedure:

i. Among all qualified bids, the lowest bid will be termed as L 1. If L 1 is 'Class-I local supplier', the contract for full quantity will be awarded to L 1.

ii. If L 1 bid is not a 'Class-I local supplier', 50% of the order quantity shall be awarded to L 1. Thereafter, the lowest bidder among the 'Class-I local supplier' will be invited to match the L 1 price for the remaining 50% quantity subject to the Class-I local supplier's quoted price falling within the margin of purchase preference, and contract for that quantity shall be awarded to such 'Class-I local supplier' subject to matching the L 1 price, In case such lowest eligible 'Class-I local supplier' fails to match the L 1 price or accepts less than the offered quantity, the next higher 'Class-I local supplier' within the margin of purchase preference shall be invited to match the L 1 price for remaining quantity and so on, and contract shall be awarded accordingly. In case some quantity is still left uncovered on Class-I local suppliers, then such balance quantity may also be ordered on the L 1 bidder.

(c) In the procurements of goods or works, which are covered by para 2(b) above and which are not divisible in nature, and in procurement of services where the bid is evaluated on price alone, the 'Class-I local supplier' shall get purchase preference over 'Class-II local supplier' as well as 'Non-local supplier', as per following procedure:

i. Among all qualified bids, the lowest bid will be termed as L 1. If L 1 is 'Class-I local supplier', the contract will be awarded to L 1.

ii. If L 1 is not 'Class-I local supplier', the lowest bidder among the 'Class-I local supplier', will be invited to match the L 1 price subject to Class-I local supplier's quoted price falling within the margin of purchase preference, and the contract shall be awarded to such 'Class-I local supplier' subject to matching the L 1 price.

iii. In case such lowest eligible 'Class-I local supplier' fails to match the L 1 price, the 'Class-I local supplier' with the next higher bid within the margin of purchase preference shall be invited to match the L 1 price and so on and contract shall be awarded accordingly, In case none of the 'Class-I local supplier' within the margin of purchase preference matches the L 1 price, the contract may be awarded to the L 1 bidder.

(d) "Class-II local supplier" will not get purchase preference in any procurement, undertaken by procuring entities.

3B. APPLICABILITY IN TENDERS WHERE CONTRACT IS TO BE AWARDED TO MULTIPLE BIDDERS :

In tenders where contract is awarded to multiple bidders subject to matching L1 rates or otherwise, the "Class-I local supplier" shall get purchase preference over 'Class-II local supplier' as well as "Non-local supplier" as per following procedure:

(a) In case there is sufficient local capacity and competition for the item to be procured as notified by the nodal Ministry, only Class-I local suppliers shall be eligible to bid. As such, the multiple suppliers, who would be awarded the contract, should be all and only 'Class-I local suppliers'.

(b) In other cases, 'Class-I local suppliers' and 'Non local suppliers' may also participate in the bidding process along with " Class-I local suppliers' as per provisions of this Order.

(c) If 'Class-I local suppliers' qualify for award of contract for at least 50% of the tendered quantity in any tender, the contract may be awarded to all qualified bidders as per award criteria stipulated in the bid documents. However, in case 'Class-I local suppliers' do not qualify for award of contract for at least 50% of the tendered quantity, purchase preference should be given to the 'Class-I local suppliers' over 'Class-II local suppliers'/ 'Non local suppliers' provided that their quoted rate falls within 20% margin of purchase preference of the highest quoted bidder considered for award of contract so as to ensure that the 'Class-I local suppliers' taken in totality are considered for award of contract for at least 50% of the tendered quantity.

(d) First purchase preference has to be given to the lowest quoting 'Class-I local suppliers', whose quoted rates fall within 20% margin of purchase preference, subject to its meeting the prescribed criteria for award of contract as also the constraint of maximum quantity that can be sourced from any single supplier. If the lowest quoting 'Class-I local suppliers', does not accept the offered quantity, an opportunity may be given to next higher 'Class-I local suppliers', failing within 20% margin of purchase preference, and so on.

(e) To avoid any ambiguity during bid evaluation process, the procuring entities may stipulate its own tender specific criteria for award of contract amongst different bidders including the procedure for purchase preference to 'Class-I local suppliers' within the broad policy guidelines stipulated in Sub-paras above.

1. EXEMPTION OF SMALL PURCHASES:

Procurements where the estimated value to be procured is less than Rs.5 Lakh shall be exempt from this Order. However, it shall be ensured by procuring entities that procurement is not split for the purpose of

avoiding the provisions of this Order.

Note : SI. No. 3B(e) and 4 mentioned above will not be included in tenders as it is only for internal guidance / approval.

2. MARGIN OF PURCHASE PREFERENCE:

The margin of purchase preference shall be 20%

3. VERIFICATION OF LOCAL CONTENT:

a) The 'Class-I local suppliers' / 'Class-II local suppliers' at the time of tender, bidding or solicitation shall be required to indicate percentage of local content and provide self-certification that the item offered meets the local content requirement for 'Class-I local suppliers' / 'Class-II local suppliers'.

In this connection, such bidders shall furnish following undertaking from the manufacturer(s) on Manufacturer's letter head along with their techno-commercial bid. The undertaking shall become a part of the contract :

"We _____ (Name of Manufacturer) undertake that we meet the mandatory minimum Local Content (LC) requirement i.e. _____ (to be filled as notified in tender as well as the said policy) for claiming purchase preference linked with Local Contents under the Govt. Policy against under tender no. _____."

b) In cases of procurement for a value in excess of Rs. 10 crores, the 'Class-I local suppliers' / 'Class-II local suppliers' shall be required to provide a certificate from the statutory auditor or cost auditor of the company (in case of companies) or from a practicing cost account or practicing chartered accountant (in respect of suppliers other than companies) giving the percentage of local content.

In this connection, such bidders shall furnish following undertaking shall be supported by the following certificate from Statutory Auditor engaged by the bidder, on the letter head of such Statutory Auditor (as per the provisions of the aforesaid policy):

"We _____ the statutory auditor of M/s _____ (name of the bidder) hereby certify that M/s _____ (name of manufacturer) meet the mandatory Local Content requirements of the Goods and/or Services i.e. _____ (to be filled as notified in tender as well as the said policy) quoted vide offer No. _____ dated _____ against the tender No. _____ by M/s _____ (Name of the bidder)."

c) Local Suppliers must note that once the declaration / certification is committed by them at tender submission stage, the same cannot be altered at technical negotiation stage or after award of contract otherwise would be treated / considered as false declaration by bidder. If it is identified that there is difference in price received and declaration made and local content is now not meeting the specified tender requirement (i.e. only on the quoted price without any loading) then such case is to be processed without any purchase preference as Non-Local Supplier

4. IN CASE OF PARTICIPATION OF MSE AND LOCAL SUPPLIER AGAINST A SAME TENDER,

In case of participation of MSE and Local Supplier against a same tender, MSE bidder will be given preference to match with L1 bidder as per Public Procurement Policy for MSEs Order 2012. MSE vendor will be evaluated with L1+15% bracket and whereas Local Supplier will be evaluated with L1+20% bracket as MSE doesn't fall under Public Procurement (Preference to Make in India) Order 2017 as per Public Procurement Policy for MSE Order 2012 and Public Procurement (Preference to Make in India) Order 2017 is not applicable for MSEs. Bidders declaring Local supplier / MSE status to seek benefits of only one policy of the two. Bidders are not to be allowed to change their status from MSE to Local supplier and visa versa.

5. IN CASE OF PARTICIPATION OF BIDDER FROM COUNTRIES WHICH SHARES A LAND BORDER WITH INDIA

Any bidder from a country which shares a land border with India will be eligible to bid in any procurement whether of goods, services (including consultancy services / non consultancy services) or works (including turnkey projects) only if the bidder is registered with the Competent Authority (as per OM dated 23.07.2020 issued by Ministry of Finance), relevant declaration format is enclosed as Annexure –B.

COMPLIANCE CERTIFICATE REGARDING BIDDERS FROM COUNTRIES WHICH SHARES A LAND BORDER WITH INDIA
(Submitted on Bidder's Letter Head)

The bidder, (Name of the bidder) is not from a country which shares a land border with India;

(or)

The bidder, (Name of the bidder) is from a country, (Name of the Country) which shares a land border with India and are registered with the Competent Authority. Certificate of registration is attached with the bid;

(or)

The bidder, (Name of the bidder) is from a country, (Name of the Country) which shares a land border with India and Government of India has extended lines of credit or is engaged in developmental projects in this country, (Name of the Country) and hence do not require any separate registration for participation in this tender.

b. I have read the Clause regarding restrictions on procurement from a bidder of a country which shares a land border with India; I certify that this bidder is not from such a country or, if from such a country, has been registered with the Competent Authority. I hereby certify that this bidder fulfils all requirements in this regard and is eligible to be considered. (Where applicable, evidence of valid registration by the Competent Authority shall be attached).

c. I have read the Clause regarding restrictions on procurement from a bidder of a country which shares a land border with India and on sub-contracting to contractors from such countries; I certify that this bidder is not from such a country or, if from such a country, has been registered with the Competent Authority and will not sub- contract any work to a contractor from such countries unless such contractor is registered with the Competent Authority. I hereby certify that this bidder fulfils all requirements in this regard and is eligible to be considered. [Where applicable, evidence of valid registration by the Competent Authority shall be attached].

Details of Vendor's authorized representative

Signature:

Name:

Stamp:

TO WHOMSOEVER IT MAY CONCERN

Legal Name of Entity :
 Trade Name of Entity :
 Registered Office Address :
 Pin :
 GSTIN :

Please select the applicable response under column C in respect of details set out in column "B".

Case No.	Aggregate Turnover at PAN level (in any preceding financial year from FY 17-18 onwards)	Select the applicable case
(A)	(B)	(C)
1.	More than INR 20 Crores	
2.	Less than or equals to INR 20 Crores	
3.	Specific category excluded from compliance to e-invoicing, as notified.	

I/We,of(hereinafter called as "the Company") do hereby declare that the aggregate turnover of "the Company" computed as per Section 2(6) of Central Goods and Service Tax Act., 2017 exceed limit prescribed for generation of an unique Invoice Registered Number (IRN) and QR code as per the provisions of Central Goods and Service Tax Act., 2017 and rules there under ("GST Law"). Accordingly, we are covered under the ambit of GST e-invoicing provisions w.e.f. 1st October,2020 and therefore, the invoices, debit notes, credit notes or any other prescribed documents under e-invoicing issued/raised by us duly compliance with the notified e-invoicing provision.

Further, any invoice or document issued by the Company to BRIDGE AND ROOF Co. (India) Ltd. having **GSTIN: 21AABCB3166E1ZB** shall be properly and timely reported under respective return under GST by the Company in line with the notified provisions and the applicable tax collected form BRIDGE AND ROOF Co. (India) Ltd. shall be timely and correctly paid to respective Government by us.

We acknowledge that information furnished above are true to the best of our knowledge. In case any of the above information is found to be incorrect at a later date or due to failure on our part to comply with the relevant laws/regulations and if any GST liability, interest, penalties or any other amount becomes payable or input tax credit is denied to BRIDGE AND ROOF Co. (India) Ltd. having **GSTIN: 21AABCB3166E1ZB**, we shall indemnify for the same.

For and on behalf of

(Signature of Authorized Signatory)

Name :

**DETAILS OF TECHINCAL and ADMINISTRATIVE
PERSONNEL TO BE EMPLOYED FOR THE WORK
As per requirement mentioned in Annexure – J**

Sl. No	Designation	Total Number	Number Available For this Work	Name	Qualification	Professional experience and details of work carried out	How these would be involved in this work	Remarks

**DETAILS OF CONSTRUCTION PLANT AND EQUIPMENT LIKELY
TO BE USED IN CARRYING OUT THE WORK
As per requirement mentioned in Annexure – I**

Sl.No.	Name of Equipment	Minimum Nos. to be deployed by the successful Bidder	Capacity of Type	Age	Condition	Ownership Status		To be Purchased	Current Location	Remarks
						Presently owned	Leased			
1.	Concrete Mixer Machine									
2.	Excavator cum Backhoe Loader									
3.	Tractor with Trolley									
4.	Concrete Vibrator									
5.	Jack Hammer / Concrete breaker									
6.	DG Set									
7.	Vibro Roller									
8.	Earth compactor									
9.	Bar Cutting & Bending machine									

The above list is exhaustive and any other equipment that may be required to complete the work within the phase/full completion period shall be deployed by the contractor as per instruction of Engineer in Charge. This is to be considered within their quoted rates and prices.

The bidder will have to submit necessary documents substantiating the ownership proof of the above equipments. In case of non-availability of ownership proof the bidder will have to submit necessary lease documents for availability of the equipments during commencement of work

Signature of Bidder

**INFORMATION REGARDING CURRENT LITIGATION, DEBARRING EXPELLING
OF BIDDER OR ABANDONMENT OF WORK BY THE BIDDER**

- | | | | |
|-----|----|--|-----------|
| 01) | a) | Is the bidder currently involved in any litigation relating to the works. | Yes / No. |
| | b) | If yes: - give details. | |
| 02) | | Has the bidder or any of its constituent partners been debarred / expelled by any agency in India during the last 5 years. | Yes / No. |
| 03) | a) | Has the bidder or any of its constituent partners failed to perform on any contract work in India during the last 5 years. | Yes / No. |
| | b) | If yes: - give details. | |

Note: If any information in this schedule is found to be incorrect or concealed, qualification application will summarily be rejected.

Signature of Bidder

Date

PREAMBLE TO SCHEDULE OF QUANTITIES and RATES

[Tenderers are required to print this on their Company's Letter head and sign, stamp before uploading]

1. The Schedule of Rates/Price shall be read with all other sections of this Bidding Document.
2. The Contractor is deemed to have studied the drawings, specifications and details of works to be done within the Time Schedule and should have acquainted himself of the conditions prevailing a site.
3. No claim shall be entertained during currency of this Contract towards any items due to the above including where the Contractor has quoted low/ high rates.
4. Owner / Consultant / B AND R reserves the right to interpolate or extrapolate the rates for any new item of work not covered in Schedule of Quantities and Rates from the similar items already available in Schedule of Quantities and Rates. All the works shall be measured upon completion and paid for at the rate quoted and accepted in the "Schedule of Quantities and Rates ". In case any activity though specifically not covered in Schedule of Quantities and Rates descriptions but the same is covered under scope of work/ scope of supply/ specification/ drawings etc. no extra claim on this account shall be entertained, since Schedule of Quantities and Rates is to be read in conjunction with all other documents forming part of the Contract.
5. All items of work mentioned in the Schedule of Quantities and Rates shall be carried out as per the specifications, drawings and instructions of Owner / Consultant / B AND R and the rates are deemed to be inclusive of material, consumable, labour, supervision, tools and tackles and detailing of construction drawings, isometric wherever required as called for in the detail specification and conditions of the Contract.
6. Owner / Consultant / B AND R reserves the right to cancel/ delete/ curtail any item or group of work if necessary. Such a step shall not be construed as reason for changing the rates.
7. The Schedule of Quantities and Rates (SOQR) rates are deemed to be inclusive of all taxes and duties i.e. **Purchase Tax, Turn Over Tax, Excise Duty, Work Contract Tax, Labour Cess or any other Tax, Royalty, all incidental expenditure including Environmental and Pollution Clearance Charges except Goods and Services Tax (GST).**
8. Bidder shall indicate "**Lumpsum Rate**" basis rounded upto two decimal places in the "Prices" sheet. Bidder shall not change rate / amount indicated in "Schedule of Quantities and Rates".
9. Bidder shall furnish the details as requested below along with this Preamble to Schedule of Quantities and Rates, to be submitted along with their price offer:

Name of authorized person submitting the tender on behalf of the Bidder (s):

Designation of authorized person:

Name of firm / Contractor:

Address of firm / Contractor:

Date:

COMPLIANCE TO BID REQUIREMENT
[To be submitted in Bidder's Letter Head]

We hereby agree to fully comply with, abide by and accept without variation, deviation or reservation all Techno-commercial Terms and Conditions and other conditions whatsoever of the NIT / Tender Documents and Addendum to the Tender and PQ- Documents, if any, for subject work issued by BRIDGE AND ROOF Co. (I) Ltd.

We hereby further confirm that any terms and conditions if mentioned in our offer shall not be recognized and shall be treated as null and void.

SIGNATURE OF BIDDER :

NAME OF BIDDER :

COMPANY SEAL :

DECLARATION BY THE BIDDER

We (**Name of the Bidder**) hereby represent that we have gone through and understood the Bidding Document (which in two parts) in Part-I (Pre-Qualification Documents, Techno-commercial Documents and relevant documents etc.) including Compliance to Bid Requirement and Part-II (Schedule of Quantities and Rates – **to be opened only the Techno-commercially recommended / Qualified bidders**) that our Bid has been prepared accordingly in compliance with the requirement stipulated in the said documents.

We are submitting a copy of Bidding Document marked “Original” as part of our Bid duly signed and stamped on each page in token of our acceptance. We undertake that Part-I and Part-II of the Bidding Document shall be deemed to form part of our bid and in the event of award of work to us the same shall be considered for constitution of Contract. Further, we shall sign and stamp each page of this Part-I including Compliance to Bid Requirement and Part-II (**to be opened only the Techno-commercially recommended / Qualified bidders**) as a token of Acceptance and as a part of the Contract in the event of award of Contract to us.

We further confirm that we have gone through the PQ Documents and Techno-commercial Terms and Conditions and shall upload Price Bid in CPP Portal as per Tender hosted by B AND R. We confirm that our quoted rates shall be included the price for all works /activities / supply etc. as per the item description of the items in Schedule of Quantities and Rates.

SIGNATURE OF BIDDER :

NAME OF BIDDER :

COMPANY SEAL :

Note: This declaration should be signed by the Bidder’s representative who is signing the Bid.

Signature of Bidder_____

BANK GUARANTEE IN LIEU OF EARNEST MONEY DEPOSIT

BG NO.: _____

DATED: _____

VALID UPTO: _____

To,
BRIDGE AND ROOF Co. (I) Limited,

Dear Sirs,

In consideration of BRIDGE AND ROOF Co. (I) Limited (hereinafter called " B AND R" which expression shall include its successors and assigns), having agreed inter-alia to consider the tender of (*Name of the Tenderer*) having its Head Office/Registered Office at (_____ *Address of Tenderer* _____) (hereafter called the "Tenderer" which expression shall include its successors and assigns), for the work of _____ according to Tender No. _____

upon the

Tenderer furnishing a Bank Guarantee with all undertaking from the Bank as hereinafter appearing in lieu of cash deposit of the Earnest Money. We _____(Name of the Bank) a Bank constituted / Registered under the_____. Act ,having our head Office / Registered Office at _____(hereinafter called the "Bank" which expression shall include Its successors and assigns), at the request of the Tenderer and with the intent to bind the Bank and its successors and assigns do hereby unconditionally and irrevocably undertake to pay the B AND R at Kolkata forthwith on first demand without protest or demur or proof or satisfaction or condition and without reference to the Tenderer, all sums payable by the Tenderer as and by way of Earnest Money to B AND R, up to an aggregate limit of Rs. _____ (Rupees _____)and the Bank doth hereby further agree as follows:

1. This Guarantee / Undertaking shall be a continuing guarantee and shall remain in full force and effect for all claims or demands made by the B AND R on the Bank until the B AND R discharges this Guarantee/Undertaking subject, however, that the B AND R shall have no claims under this Guarantee/Undertaking after the midnight of _____ 20____ or any written extension(s) thereof. PROVIDED that if the aforesaid work tendered for or any part thereof shall be awarded to the Tenderer on or before the said date, whether on the basis of accompanying tender or any other basis, then the validity of this guarantee/undertaking shall stand automatically Extended for all claims and demands made by the B AND R for further three months.

2. The B AND R shall have the fullest liberty without reference to the Bank and without affecting in any way the liability of the Bank under this Guarantee/Undertaking at any time and/or from time to time to postpone and/or vary any of the powers, rights, and obligations exercisable by the B AND R against the Tenderer and either to enforce or to forbear from enforcing ail or any of the terms and conditions of or governing the said Tender and/or any Contract consequent upon any award of work or the said Earnest Money Deposit or the securities available to the B AND R or any of them and the Bank shall not be released from Its liability under these Presents end the liability of the Bank hereunder shall remain in Full force and effect notwithstanding any exercise by the B AND R of the liberty with reference to any of all the matters aforesaid or by reason or any other act, matter or thing whatsoever which under law relating to the sureties or otherwise which could, but for this provision have the effect of releasing the Bank from all or any of its obligations hereunder or any part thereof, and the Bank Specifically waives any and all contrary rights whatsoever.

Contd. – P/2

3. It shall not be necessary for the B AND R to proceed against the Tenderer before proceeding against the Bank and the Guarantee/Undertaking herein contained shall be enforceable against the Bank as principal debtor notwithstanding the (existence of any other undertaking or security for any indebtedness of the Tenderer to the B AND R and notwithstanding that any such security shall at the time when claim is made against the Bank or proceedings taken against the Bank hereunder, be outstanding or unrealized.

4. The amount stated by the B AND R in any demand, claim or notice made with reference to this guarantee shall as between the Bank and the B AND R for the purpose of these Presents is conclusive of the amount payable by the Bank to the B AND R hereunder.

5. The liability of the Bank to the B AND R under this Guarantee/Undertaking shall remain in full force and effect notwithstanding the existence of any difference or dispute between the Tenderer and the B AND R, the Tenderer and the Bank and/or the Bank and the B AND R or otherwise howsoever touching these Presents or the liability of the Tenderer to the B AND R, and notwithstanding the existence of any instructions or purported instructions by the Tenderer or any other person to the Bank not to pay or for any cause withhold or defer payment to the B AND R under these Presents, with the intent that notwithstanding the existing of such difference dispute or instructions, the Bank shall be and remain liable to make payment to the B AND R in terms thereof.

6. This Guarantee/Undertaking shall not be determined or affected by the liquidation or winding up or dissolution or change of constitution or insolvency of the Tenderer or any change in the legal constitution of the Bank or the B AND R.

7. Without prejudice to any other mode of service, a demand or claim or other communication may be transmitted by the B AND R to the Bank either by post or by fax, if transmitted by fax, the transmission shall be complete as soon as acknowledged by Bank.

8. Notwithstanding anything contained herein:

i) The Bank's liability under this guarantee / undertaking shall not exceed (Amount in figures and words);

ii) This guarantee / undertaking shall remain in force up to _____ and any extension(s) therefore; and

iii) The Bank shall be released and discharged from all liability under this guarantee / undertaking unless a written claim or demand is issued to the Bank on or before _____ or the date of expiry of any extension(s) thereof if this guarantee / undertaking has been extended.

The Bank doth hereby declare that Shri _____ who is authorized to sign this Guarantee / Undertaking on behalf of the Bank and to bind the Bank thereby.

This _____ day of _____ 20 _____

Yours faithfully,

Signature: _____

Name and Designation: _____

Name of the Branch: _____

FORM OF BANK GUARANTEE IN LIEU OF SECURITY DEPOSIT

(To be executed on Non-Judicial Stamp Paper of Rs. 100/-)

BRIDGE AND ROOF CO. (INDIA).LTD.,
Kankaria Centre, (4th & 5th Floor),
2/1, Russel Street,
Kolkata - 700 071.

Dear Sirs,

In consideration of BRIDGE AND ROOF CO.(INDIA).LTD. (hereinafter called "The Company" which expression shall include its successors and assign) having awarded certain work for and relative to.....
..... (name of the project/work) to (name & address of the contractor) (hereinafter called the "Contractor") upon certain terms & conditions inter-alia mentioned in the Company's Letter of Intent No./Work Order No..... dated..... (hereinafter called the Contract, which expression shall include any formal contract entered into between the Company and the Contractor and all amendments and/or modifications in the Contract) inclusive of the condition that the Company may accept a Bank Guarantee of a Scheduled Bank in India in lieu of Cash Deposit of the Security Deposit as provided for in Clause No..... of the Contract :

We, a body registered/constituted under(name of the Bank) the having registered and Head Office at.....(hereinafter called "the Bank") at the request of the Contractor and with the intent to bind the Bank and its successors and permitted assigns, do hereby unconditionally and irrevocably guarantee payment to the company of the unpaid balance of the Security Deposit upto an aggregate limit of Rs.....(Rupees..... Only) AND undertake to pay the Company on demand & without protest or demur the unpaid balance of said Security deposit subject to the aggregate limit aforesaid of Rs.....(Rupees.....only).

AND the Bank do hereby further agree as follows :

1. The Guarantee/undertaking herein contain shall remain in full force and effect during the period that would be taken for the performance of the said contract and the claim of the Company relative thereto satisfied and/or discharged and the Company accordingly discharge the Guarantee/undertaking subject, however, that the Company shall have no claim under this Guarantee/undertaking after20....., unless a notice of the claim under this Guarantee/undertaking has been served on the Bank before the expiry of the said date, in which event the same shall be enforceable against the Bank notwithstanding that the same is enforced after the expiry of the said date namely
2. The Company shall have the fullest liberty without reference to the Bank and without affecting in any way the liability of the Bank under this Guarantee/undertaking, at any time and/or from time to time to anywise vary the said Contract and/or any of the terms & conditions thereof or relative to the said Security Deposit or to extend time of performance of the said Contract in whole or part or to postpone for any time and/or from time to time any of the obligations of the Contractor and/or power exercisable by the Company against the Contractor & either to enforce or forbear from enforcing any of the terms and conditions of or governing the said Contract or the said Security Deposit or the Securities available to the Company or any of them and the Bank shall not be released from its liability under these presents & the liability of the Bank shall remain in full force and effect notwithstanding any exercise by the Company of the liberty with reference to any or all the matters aforesaid or by reason of time being given to the Contractor or any other forbearance, act or omission on the part of the Company or any indulgence by the Company to the Contractor or of any other act, matter or thing whatsoever which under the law relating to sureties would, but for this provision, have the effect of releasing the Bank from its liability hereunder or any part thereof.

3. It shall not be necessary for the Company to proceed against the Contractor before proceeding against the Bank and the Guarantee/undertaking herein contained shall be enforceable against the Bank notwithstanding the existence of any other security for any indebtedness of the Contractor to the Company (including relative to the said Security Deposit) and notwithstanding that any such security shall at the time when claim is made against the Bank or proceedings taken against the Bank hereunder, be outstanding or unrealized.
4. The amount stated by the Company in any demand, claim or notice as the unpaid balance of the said security deposit for the time being shall as between the Bank and the Company for the purpose of these presents be conclusive of the said balance.
5. The liability of the Bank to the Company under this Guarantee/undertaking shall remain in full force and effect notwithstanding the existence of any difference or dispute between the Contractor and the Company, the Contractor and the Bank/and or the Bank and the Company, or otherwise whatsoever touching or affecting these presents or the liability of the Contractor to the Company, and notwithstanding the existence of any instructions or purported instructions by the Contractor or any other person to the Bank not to pay or for any cause withhold or defer payment to the Company under these presents, with the intent that notwithstanding the existence of such difference, dispute or instruction, the Bank shall be and remain liable to make payment to the Company in terms hereof.
6. The Bank shall not revoke this Guarantee/undertaking during its Currency except with the previous consent of the company in writings and also agree that any change in the constitution of the Contractor or the Bank or the Company shall not discharge the Bank's liability hereunder.
7. Notwithstanding anything herein contained our liability under this guarantee is restricted to Rs..... and our guarantee shall remain in full force till (date) unless a suit or action to enforce the claim under this guarantee(date) is filed against Bank within three month from the above date i.e., on or before (date) all your rights under the said guarantee shall be forfeited and Bank shall be relieved and discharged from all liabilities there under.
8. The Bank doth hereby declare that Shri
(name of the person signing on behalf of the Bank) who is (his designation)
authorized to sign this Guarantee/undertaking on behalf of the Bank & to bind the Bank thereby.

Dated thisday of20....

Yours faithfully,

For

Signature

Name & Designation

Name of the Branch

RESPONSIBILITY MATRIX (SITE INFRASTRUCTURE & OTHER)

Sl. No.	Activity	SCOPE OF B&R	SCOPE OF BIDDER
1	Construction Drawing	√	-----
2	labour hutment	-----	√
3	Electricity/Construction water (Up to a point source)	-----	√
4	All required Materials for execution of work	-----	√
5	Reinforcement Steel and Structural Steel	-----	√
6	All required Equipments, Machineries, Tools tackles.	-----	√
7	Supervision & Inspection	√	√
8	Deployment of Engineer, Supervisor Un-skilled, Semi-skilled & Skilled labour	----	√
9	All incidental Works.	----	√
10	Accommodation & Transportation of Contractor's Employees/ Workers	----	√
11	Liaise assistance with Statutory authority and local administration for smooth execution.	----	√
12	Labour License	√	----
13	All types of personal protective equipment & accessories.	----	√
14	Submission of Material Test Certificate	----	√
15	Compliance of all Statues like PF, ESIC & GST. etc.	----	√

- Note: M/S B&R may issue items to the Agency (covered under agency's scope) on Chargeable basis with GST. subject to availability at B&R's Store.
- The above list is non-exhaustive. Any other materials, facilities etc. are required for completion of the entire work, shall be under the Agency's Scope and shall be included within their Quoted Rates.

For & On behalf of the Tenderer

BRIDGE AND ROOF COMPANY (INDIA) LIMITED

CIN No.: U27310WB1920GOI003601

Santragachi Station Development Work site,
1st Floor, New Station Building, Platform No. 6
Santragachi, PIN- 711 111, West Bengal

NOTICE INVITING TENDER (NIT) No.:B AND R/51110/TD/SC/RCC ROAD WORK/01 DTD. 13/06/2024

EXECUTION OF RCC ROAD ALONG WITH FOOTPATH, DRAINAGE AND MISCELLANEOUS FINISHING WORK ON SUB-CONTRACT BASIS IN CONNECTION WITH "CONSTRUCTION OF NEW ISLAND PLATFORM AND REFURBISHING OF EXISTING PLATFORMS INCLUDING PLATFORM SHADE AT SANTRAGACHI RAILWAY STATION REGARDING STATION DEVELOPMENT WORK FOR SOUTH EASTERN RAILWAY IN WEST BENGAL

ANNEXURE - V

SCHEDULE OF QUANTITIES & RATES

BRIDGE AND ROOF COMPANY (INDIA) LIMITED

CIN No.: U27310WB1920GOI003601
Santragachi Station Development Work site,
1st Floor, New Station Building, Platform No. 6
Santragachi, PIN- 711 111, West Bengal

NOTICE INVITING TENDER (NIT) No.:B AND R/51110/TD/SC/RCC ROAD WORK/01 DTD. 13/06/2024

EXECUTION OF RCC ROAD ALONG WITH FOOTPATH, DRAINAGE AND MISCELLANEOUS FINISHING WORK ON SUB-CONTRACT BASIS IN CONNECTION WITH "CONSTRUCTION OF NEW ISLAND PLATFORM AND REFURBISHING OF EXISTING PLATFORMS INCLUDING PLATFORM SHADE AT SANTRAGACHI RAILWAY STATION REGARDING STATION DEVELOPMENT WORK FOR SOUTH EASTERN RAILWAY IN WEST BENGAL

ANNEXURE - VI

TECHNICAL SPECIFICATION

BRIDGE AND ROOF COMPANY (INDIA) LIMITED

CIN No.: U27310WB1920GOI003601
Santragachi Station Development Work site,
1st Floor, New Station Building, Platform No. 6
Santragachi, PIN- 711 111, West Bengal

NOTICE INVITING TENDER (NIT) No.:B AND R/51110/TD/SC/RCC ROAD WORK/01 DTD. 13/06/2024

EXECUTION OF RCC ROAD ALONG WITH FOOTPATH, DRAINAGE AND MISCELLANEOUS FINISHING WORK ON SUB-CONTRACT BASIS IN CONNECTION WITH "CONSTRUCTION OF NEW ISLAND PLATFORM AND REFURBISHING OF EXISTING PLATFORMS INCLUDING PLATFORM SHADE AT SANTRAGACHI RAILWAY STATION REGARDING STATION DEVELOPMENT WORK FOR SOUTH EASTERN RAILWAY IN WEST BENGAL

ANNEXURE - VII

SAFETY PRECAUTIONS

SAFETY PRECAUTIONS

- a) Contractor shall be vigilant to ensure provisions of relevant statute as applicable in respective working area(s).
- b) Contractor is responsible for collecting copies of prevailing rules from safety department.
- c) Contractor must ensure use of personal protective equipment by their workers while they are on job.
- d) Personal protective equipment to be supplied by the contractor to their workers must be approved by safety department of the plant before commencement of work.
- e) Although the responsibility of providing PPE rests on the contractor, as per terms of contract, may issue PPE to these workers in the interest of work if the contractor fail to provide the same and the cost of the same will be deducted from the contractor's bill. Safety department will issue such PPE with intimation to the concerned department and the contractor for necessary recovery of the cost.
- f) The contractor shall ensure periodic testing / examination of equipment as well as safety of tools and tackles, used by them, as per provision of the relevant statute and maintain the upto date record for the same at site for inspection of departmental engineer / safety department on demand.
- g) The contractor will ensure medical examination of its workers who are working at hazardous areas before commencement of work and once in every year by statutory qualified medical practitioners as per provision of the relevant statute and maintain a register for the same for inspection by respective department and safety department on demand.
- h) The workers employed by the contractors should be suitably skilled for the respective job requirement otherwise head of concerned department shall have the right to disallow the unsuitable workers. The contractor shall engage suitable number of supervisors to ensure safety at all places of work during execution of the work.
- i) In case of injury, contractor will send the injured person to hospital / dispensary / first aid centre with due intimation to the concerned department under whom he works as well as to safety and HR&A department. The contractor shall submit periodical progress report about the treatment till the injured worker is certified fit by govt. / govt. registered doctor and the said fit certificate will be submitted to safety department before resumption of work by the said injured workers.
- j) The contractor shall report about serious injury / fatality of his workers to safety department, HR&A department and concerned department then and there without fail.
- k) Contractor will be solely and wholly responsible for accident that may occur during the progress of the work and for injury or damage to person or property or any description whatsoever which may be caused by or result from the execution of the work.

Codes etc to be complied with :

The Contractor shall ensure and arrange at his cost fire and the safety provisions, as per safety code of WDO, Indian Standards Institution, safety manuals of the Employer, if any, and such provisions as are locally in force from time to time for all labour, directly or indirectly employed in the works for performance of this Contract. The Contractor will indemnify the Employer from any consequence arising due to Contractor's failure in respect of safety provisions.

First Aid and Industrial Injuries

- a) First aid facilities at easily accessible place shall be provided by the Contractor as per provisions of Labour Act or Rules of the Authority controlling the area where work is carried out.
- b) The Contractor shall make arrangements with hospitals for ambulance service and for treatment of industrial injuries to meet eventualities leading to the need for such facilities. The Engineer shall be informed of their telephone numbers and addresses of the Hospitals.
- c) Details of all critical industrial injuries shall be reported promptly to the Engineer.
- d) Report shall cover type, nature, cause, physician's report and action for prevention of those types again.

General Safety Rules

Smoking within the building premises, restricted areas, closed areas, near storage place of lubricant oil and fuel etc. is strictly prohibited.

The Contractor shall erect and maintain barricades required in connection with his operation to guard or protect

- a) Excavation
- b) Hoisting/lifting
- c) Slab openings
- d) Hazardous areas
- e) Employer's existing property likely to be subjected to damage by the Contractor's operations
- f) Unloading spots

Accidents - Precautions at Worksite

No materials on the sites shall be so stacked or placed as to cause danger or inconveniences to any person or to the public. The Contractor shall provide all necessary fencing and lights to protect the public from accidents and shall be bound to bear expenses of defence of every suit, action or other proceedings at law, that may be brought by any person, for injury sustained, owing to neglect of the above precautions and to pay any damages and costs which may be awarded in any such suit, action or proceeding, to any such person or which may, with the consent of the Contractor be paid to compromise any claim by any such person.

Electrical Equipments - Precautions

All temporary and permanent electrical installations, power distribution and supply required for execution of Work shall be carried out conforming to existing industrial and domestic safety rules and regulations. Important specific points to be noted are as under,

- i) Meter room and main switches should be freely accessible at all times and fully protected against all weather conditions.
- ii) Power distribution system shall be identifiable with display marking on switches.
- iii) All power distribution shall be carried out with coated, adequately insulated and of appropriate current/load rating cables. It shall be securely routed for this purpose. No loose, naked, hanging wires shall be permitted.
- iv) Over load protection devices shall be installed whenever and wherever heavy current/load consuming construction plant or machinery susceptible to hazard is in use and as directed by the Engineer-in-charge.
- v) Metallic plugs and sockets shall be used in field work. Switch board shall be in close proximity so as to have quick control over the supply.
- vi) Proper and adequate earthing connection should be provided for all installations, plant and machinery and distribution system.
- vii) Hand lamps and inspection lamps shall be adequately insulated and guarded with wire mesh and should have proper plugs for use.
- viii) Security and illuminatory light shall be secured firmly and protected to withstand all weather

conditions.

Maintenance of Safety Devices

All scaffolds, ladders and other safety devices mentioned or described herein shall be maintained in a safe condition and no scaffold, ladder or equipment shall be altered or removed while it is in use. Adequate washing and maintenance facilities shall be provided at or near places at work.

Personal Safety

- a) All necessary personal safety equipment as considered adequate by the Engineer shall be available for use of persons employed on the Site and maintained in a condition suitable for immediate use and the Contractor shall take adequate steps to ensure proper use of equipment by those concerned.
- b) Workers employed on mixing asphaltic materials, cement, and lime mortars/concrete shall be provided with protective footwear and protective gloves.
- c) Those engaged in handling any materials which are injurious to eyes shall be provided with protective goggles.
- d) Workers employed on erection works, etc. shall be provided with helmets, safety belts etc.
- e) Workers employed on concrete finishing, welding, painting and other works above 2 metres height shall be provided with a suitable safety belt, as per Factory Rules of the locality.

Storing Fuel, Oil and Lubricant

The Contractor shall take approval from the Safety Officer of the Employer for storing the lubricants, oil and fuel at site for running the machinery required for the construction.

Fire Extinguishing

Suitable, sufficient number of fire extinguishers for all types of fire, shall be provided at work site. In addition, sufficient number of fire buckets filled with water and sand shall also be provided. The firefighting equipment as outlined above shall be dispersed in a suitable and purposeful manner.

Fire Precautions

The Contractor shall comply with regulations of the controlling authority in force at the site of the works relating to the precautions to be taken against fire hazards.

Protection arrangements at work site

Adequate protection against any form of damage or deterioration shall be provided for in all sections of the works. This shall include protective tapes, casings, guard rails and the likes, which shall be provided as necessary. Particular care shall be taken to protect finished surfaces during the execution of adjacent in-situ work. The Contractor shall carryout all steps necessary and comply with the directions and instructions of the Engineer to his satisfaction.

Safety Arrangements for labour

The Contractor shall, at his own expense, arrange for the safety provisions as given above and as required by the Engineer, in respect of all labour directly or indirectly employed for performance of the work and shall provide all facilities in connection therewith. In case the Contractor fails to make arrangements to provide necessary facilities as aforesaid, the Engineer shall be entitled to do so and recover the cost thereof, from the Contractor.

BRIDGE AND ROOF COMPANY (INDIA) LIMITED

CIN No.: U27310WB1920GOI003601
Santragachi Station Development Work site,
1st Floor, New Station Building, Platform No. 6
Santragachi, PIN- 711 111, West Bengal

NOTICE INVITING TENDER (NIT) No.:B AND R/51110/TD/SC/RCC ROAD WORK/01 DTD. 13/06/2024

EXECUTION OF RCC ROAD ALONG WITH FOOTPATH, DRAINAGE AND MISCELLANEOUS FINISHING WORK ON SUB-CONTRACT BASIS IN CONNECTION WITH "CONSTRUCTION OF NEW ISLAND PLATFORM AND REFURBISHING OF EXISTING PLATFORMS INCLUDING PLATFORM SHADE AT SANTRAGACHI RAILWAY STATION REGARDING STATION DEVELOPMENT WORK FOR SOUTH EASTERN RAILWAY IN WEST BENGAL

ANNEXURE - VIII

TENDER DRAWINGS

SCHEDULE OF QUANTITIES AND RATES (SOQR)

EXECUTION OF RCC ROAD ALONG WITH FOOTPATH, DRAINAGE AND MISCELLANEOUS FINISHING WORK ON SUB-CONTRACT BASIS IN CONNECTION WITH "CONSTRUCTION OF NEW ISLAND PLATFORM AND REFURBISHING OF EXISTING PLATFORMS INCLUDING PLATFORM SHADE AT SANTRAGACHI RAILWAY STATION REGARDING STATION DEVELOPMENT WORK FOR SOUTH EASTERN RAILWAY IN WEST BENGAL

NOTICE INVITING TENDER (NIT) No.: B AND R/51110/TD/SC/RCC ROAD WORK/01 DTD. 13/06/2024

LABOUR SCHEDULE				Quoted Percentage to be entered by the Bidder	
SL. No.	Description	Unit	Total Quantity	Unit Rate (Excluding GST) (Rs.)	Amount (Rs.)
SCHEDULE - A/1					
1	Earth work				
1.01	Earth work in excavation of foundation trenches or drains, in all sorts of soil (including mixed soil but excluding laterite or sandstone) including removing, spreading or stacking the spoils within a lead of 75 m. as directed. For all kinds of soil and depth	cum	750.000	417.36	313020.00
2	Brick Flat Soling				
2.01	Single Brick Flat Soling of picked jhama bricks including ramming and dressing bed to proper level and filling joints with local sand.	sqm	100.000	430.58	43058.00
3	Add for using extra cement in the items of design mix over and above the specified cement content there in.	Qtl	600.000	856.32	513792.00
4	Formwork :				
4.01	Centering and shuttering including strutting, propping etc. and removal of form for :				
(i)	Foundations, footings, bases of columns, etc.	Sqm	500.000	251.07	125535.00
5	Brickwork :				
5.01	Brick work including providing common burnt clay F.P.S.(Non modular) bricks of class designation 7.5 in foundation and plinth in: cement mortar 1:6(1 cement : 6 coarse sand)	Cum	50.000	7330.22	366511.00
5.02	Half brick masonry including providing with common burnt clay F.P.S.(Non modular) bricks of class designation 7.5 in superstructure above plinth level upto floor level in all shapes and sizes in 1:4 cm (1 cement : 4 coarse sand)	Sqm	50.000	670.03	33501.50
5.03	Cement Plaster (In Coarse Sand) 1)20mm Thick Cement Plaster Of Mix 1:6 including providing Cement.	Sqm	200.000	237.75	47550.00
SCHEDULE - A/2					
6	Plain / Reinforced Cement concrete				
6.01	Providing and laying in position cement concrete of specified grade excluding the cost of centering and shuttering - All work up to plinth level :				
6.02	1:2:4 (1 Cement : 2 coarse sand : 4 graded stone aggregate 20mm nominal size)	cum	500.000	5935.16	2967580.00
6.03	Design Mix Concrete Providing and laying in position machine batched and machine mixed design mix M-25 grade cement concrete.....				
(i)	All works upto plinth level	cum	1320.000	6632.78	8755269.60
SCHEDULE - B/1					
7	Steel Reinforcement :				
7.01	Steel reinforcement for R.C.C. work including straightening, cutting, bending, placing in position and binding all complete upto plinth level including providing of R/F Steel.				
	Thermo-Mechanically Treated bars	MT	70.000	72252.43	5057670.10

SCHEDULE OF QUANTITIES AND RATES (SOQR)

EXECUTION OF RCC ROAD ALONG WITH FOOTPATH, DRAINAGE AND MISCELLANEOUS FINISHING WORK ON SUB-CONTRACT BASIS IN CONNECTION WITH "CONSTRUCTION OF NEW ISLAND PLATFORM AND REFURBISHING OF EXISTING PLATFORMS INCLUDING PLATFORM SHADE AT SANTRAGACHI RAILWAY STATION REGARDING STATION DEVELOPMENT WORK FOR SOUTH EASTERN RAILWAY IN WEST BENGAL

NOTICE INVITING TENDER (NIT) No.: B AND R/51110/TD/SC/RCC ROAD WORK/01 DTD. 13/06/2024

LABOUR SCHEDULE				Quoted Percentage to be entered by the Bidder	
SL. No.	Description	Unit	Total Quantity	Unit Rate (Excluding GST) (Rs.)	Amount (Rs.)
SCHEDULE - D					
8	Supplying, spreading and compacting Sand to required thickness, in layers not exceeding 150 mm to proper gradient and camber by ramming wherever necessary	Cum	2400.000	1045.19	2508456.00
a	Total estimated Amont				2,07,31,943.20
b	Quoted Percentage in figures (Rounded upto two decimals) above / below / at per (strike out whichever is not applicable)			Above _____ % Below _____ % At par _____ %	
c	Quoted Percentage in Words:				
d=(a x b)	Quoted Amount in figures:				
e	Quoted Amount in Words:				
f= (a+d)	Total Quoted Amount Excluding GST [In Fugure] =				
g	Total Quoted Amount in words:				

Note : In case of discrepancy between quoted percentage & amount, percentage shall prevail.

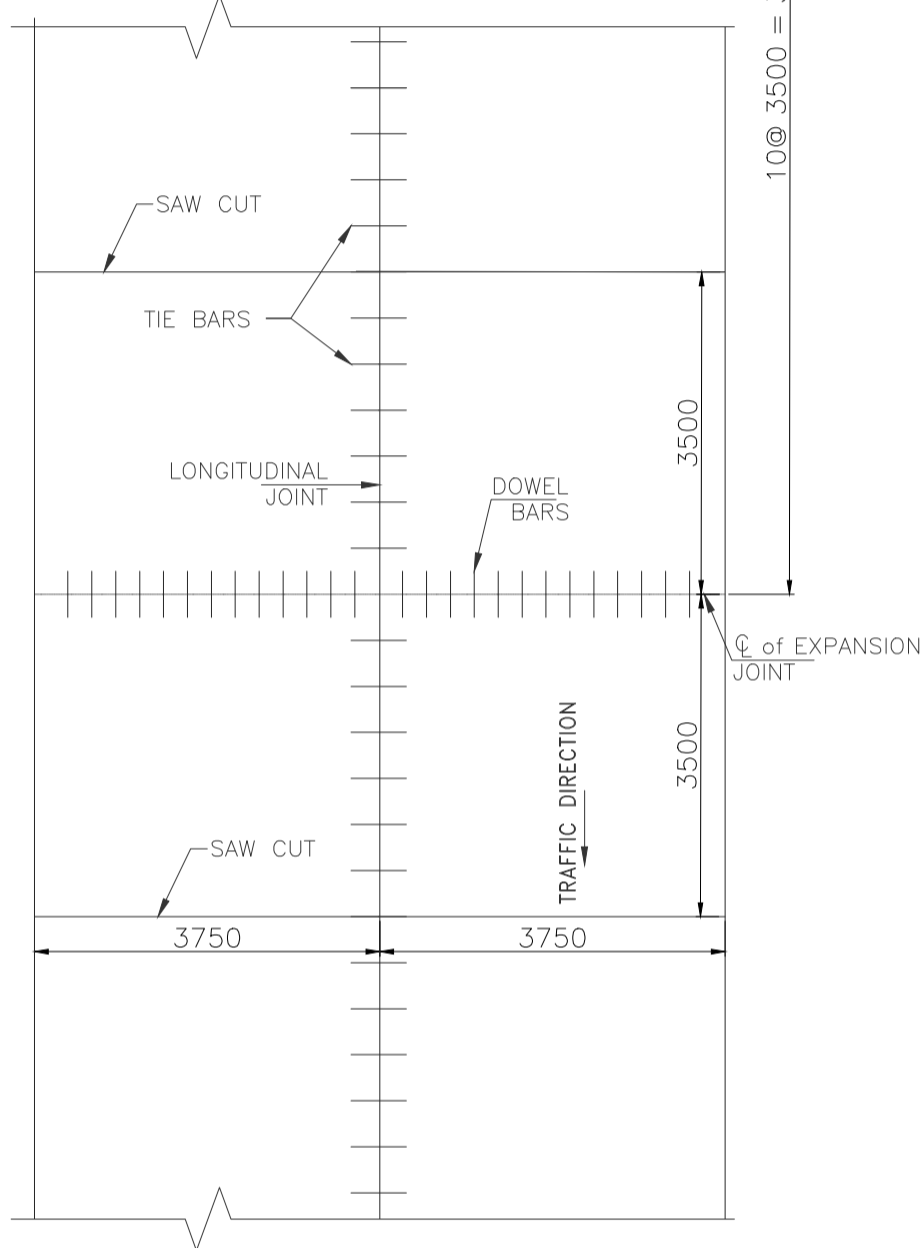
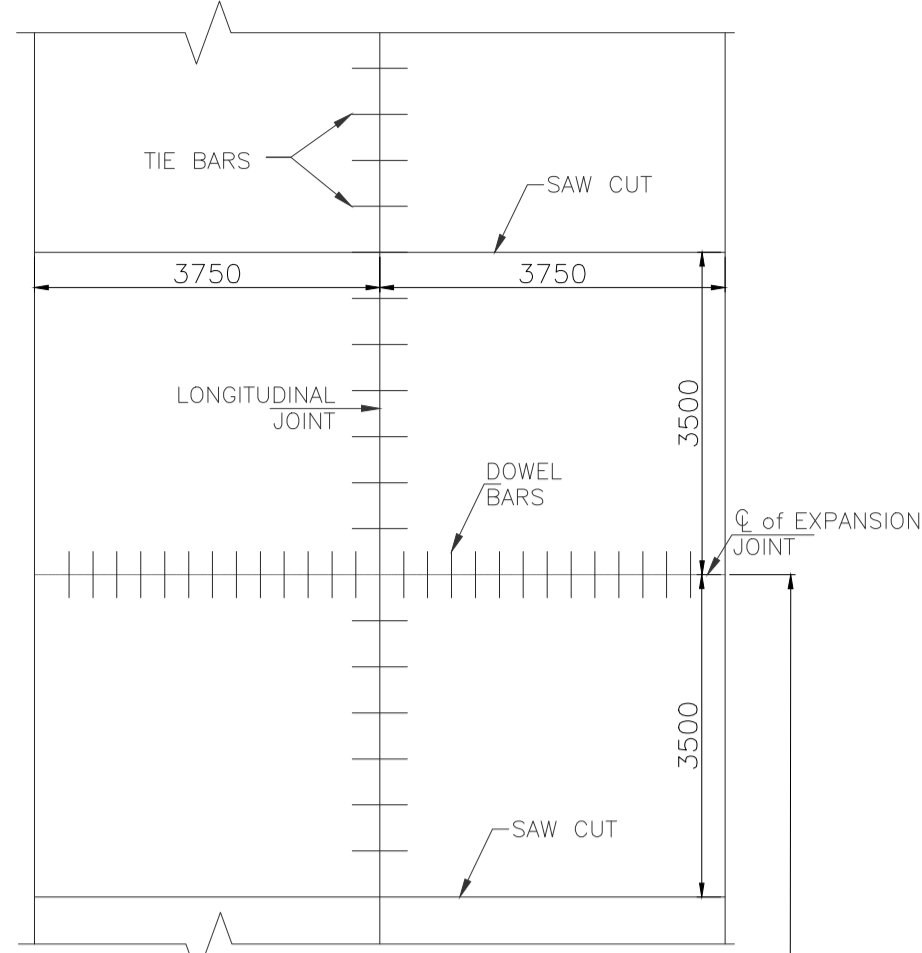

TYPICAL LAYOUT OF CONCRETE PANELS

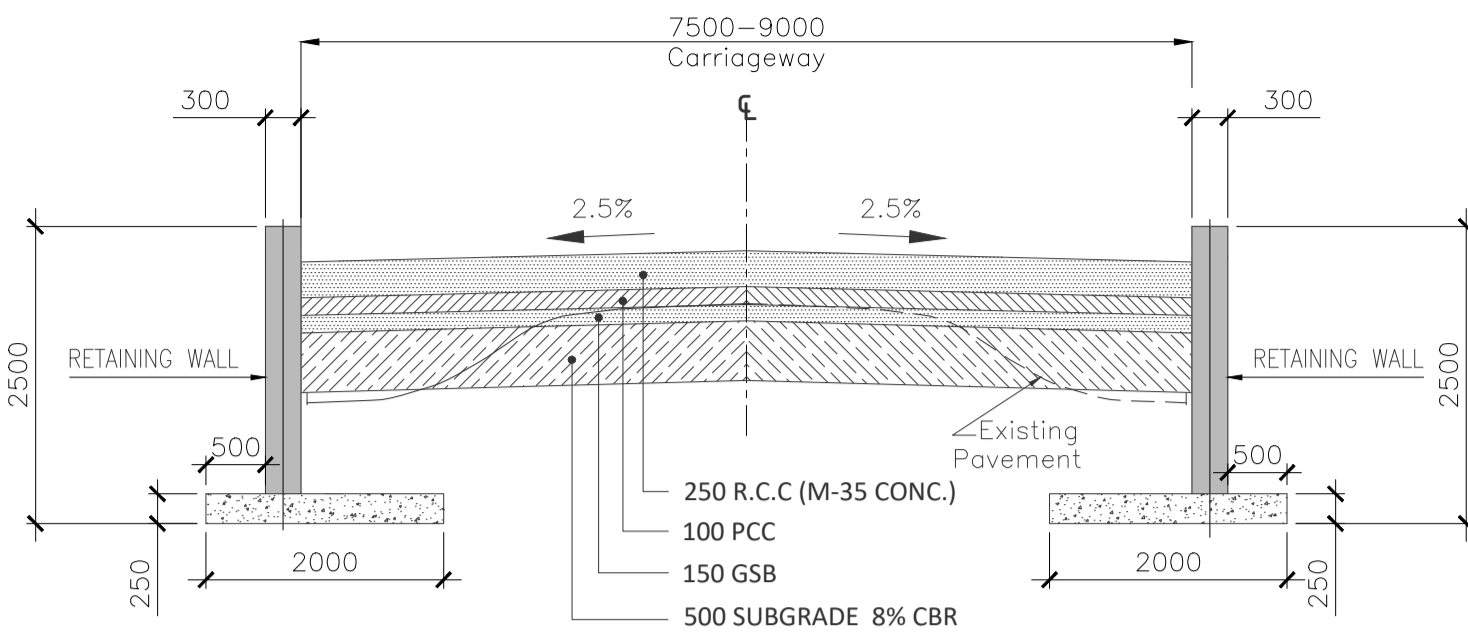

TYP. DETAIL OF ROAD WITH DRAIN

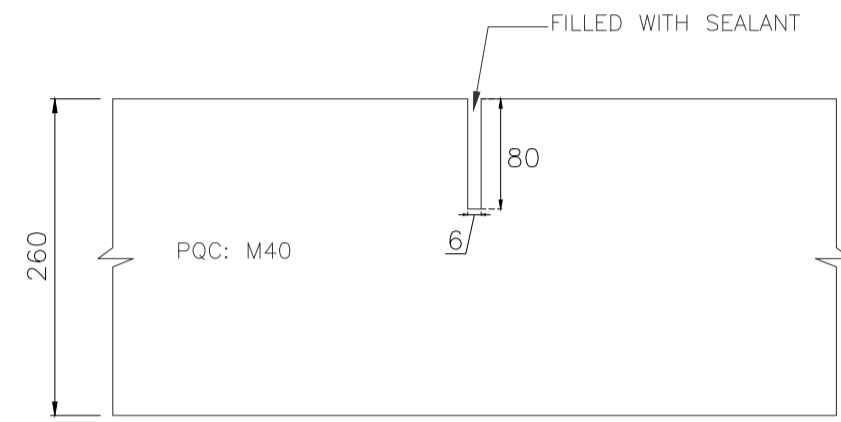

A: DETAILS OF SAW CUT

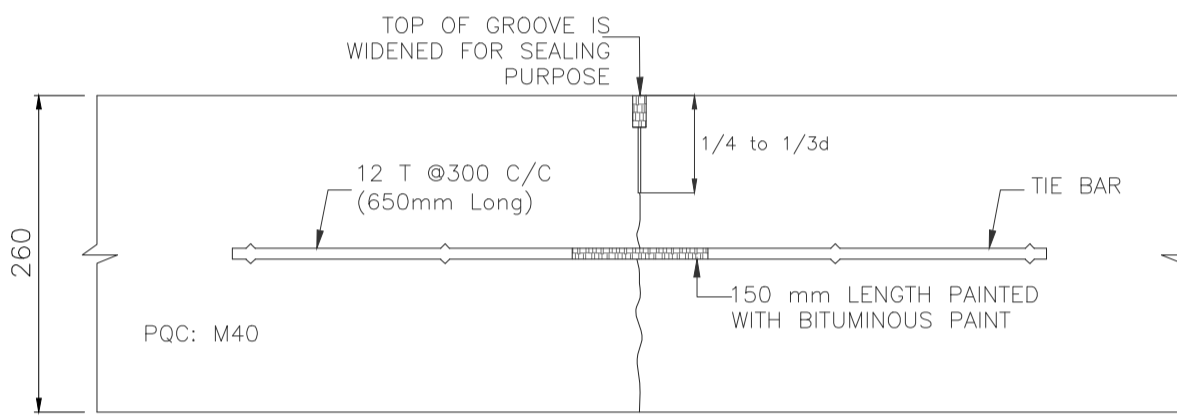

B: LONGITUDINAL JOINT WITH TIE - ROD BETWEEN TWO LANES

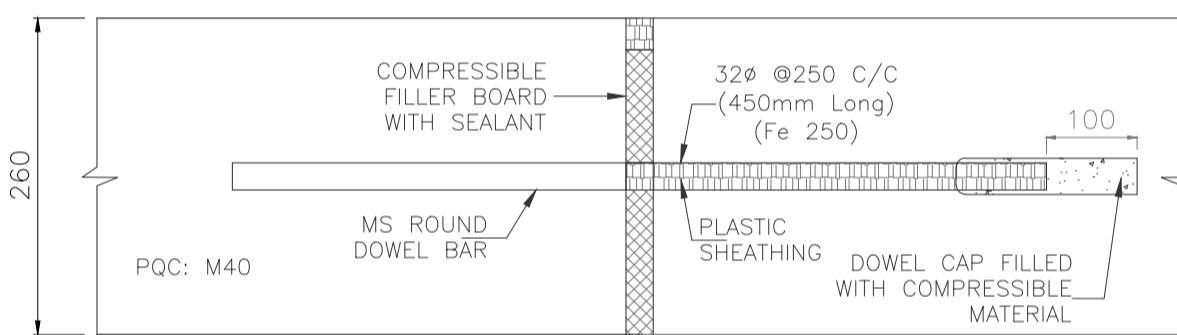

C: EXPANSION JOINT WITH DOWEL

TYPICAL CROSS SECTION OF JOINTS

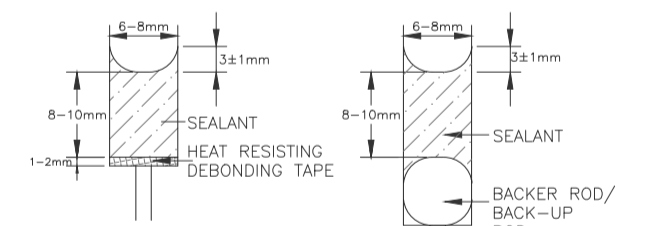

LONGITUDINAL JOINT

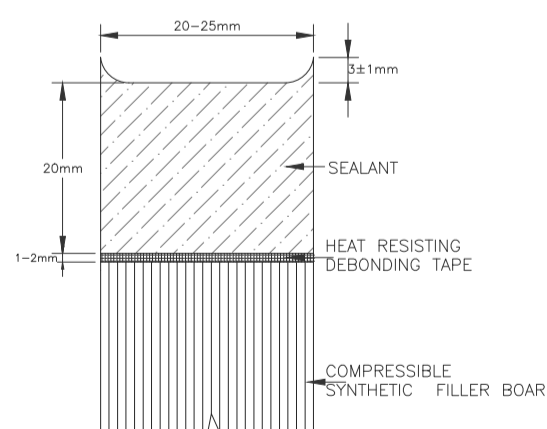

EXPANSION JOINT

SEALING DETAILS OF JOINTS (BITUMEN SEALANT)

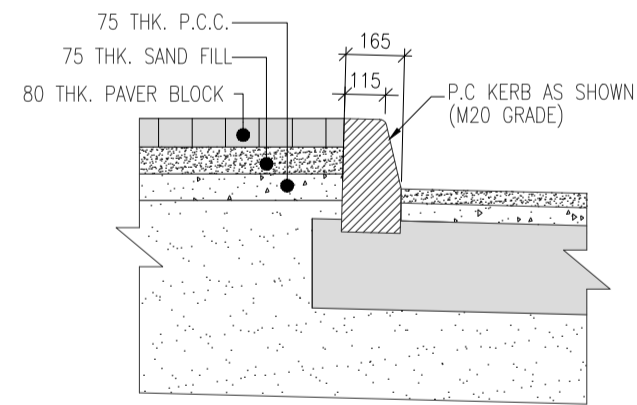

DETAIL 'A'
(SCALE: 1:20)

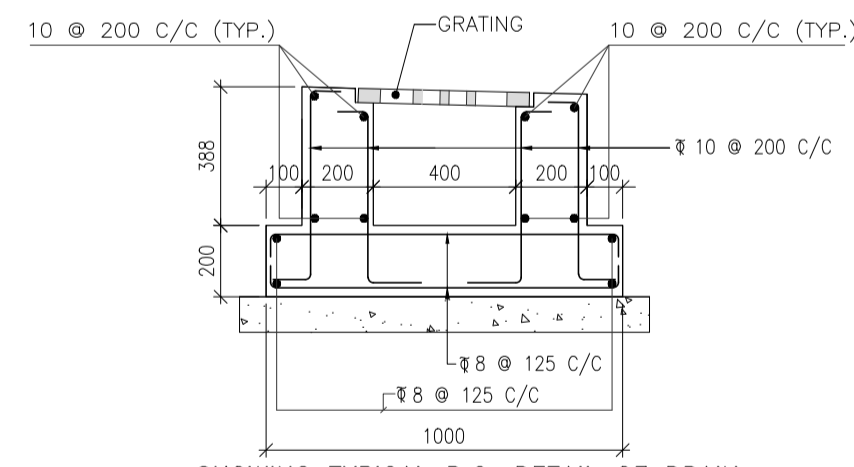

SHOWING TYPICAL R.C. DETAIL OF DRAIN
(SCALE-1:20)

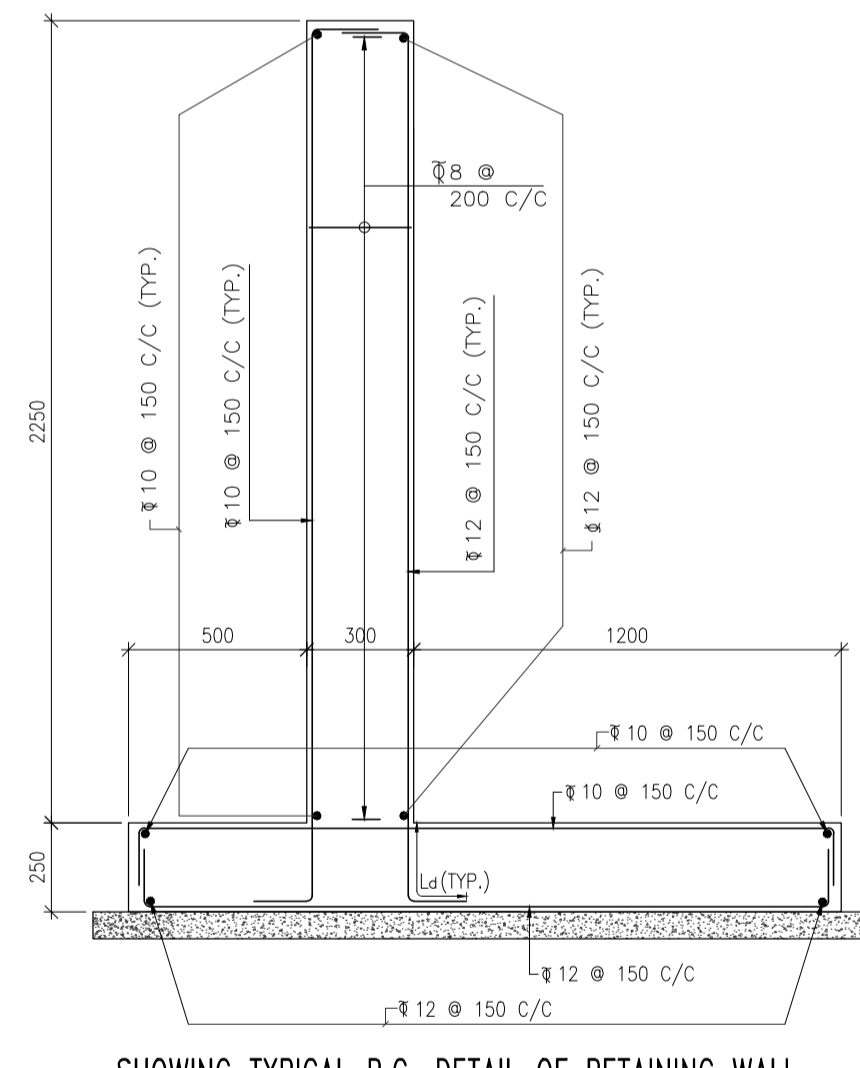

SHOWING TYPICAL R.C. DETAIL OF RETAINING WALL
(SCALE-1:20)

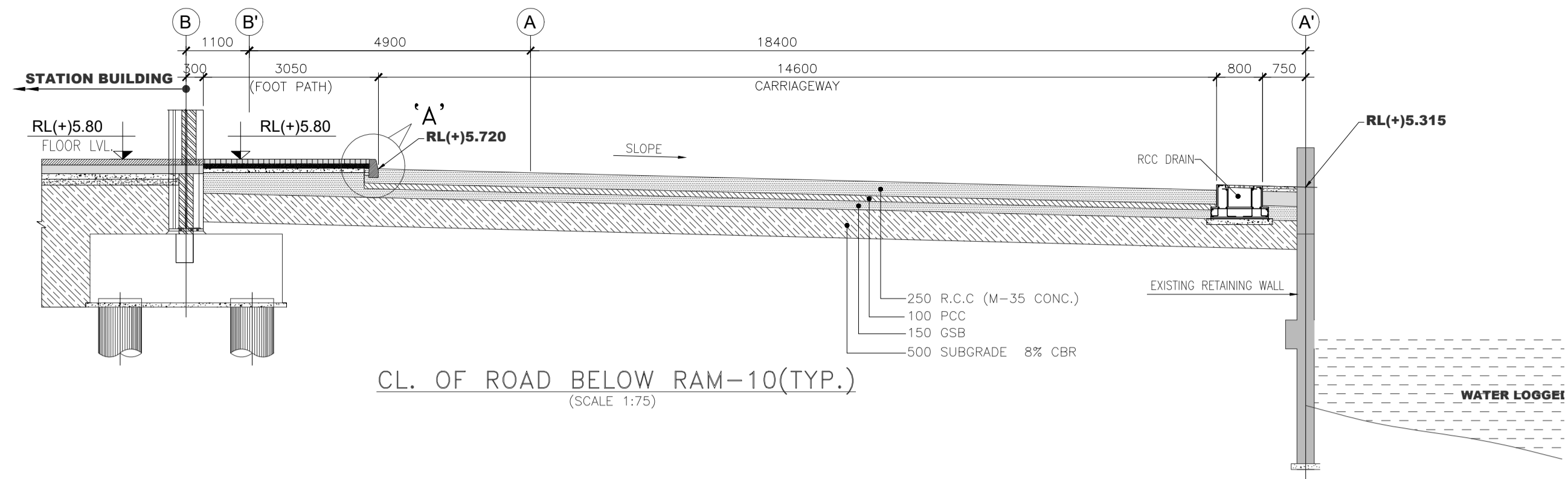

CL. OF ROAD BELOW RAM-10(TYP.)
(SCALE 1:75)

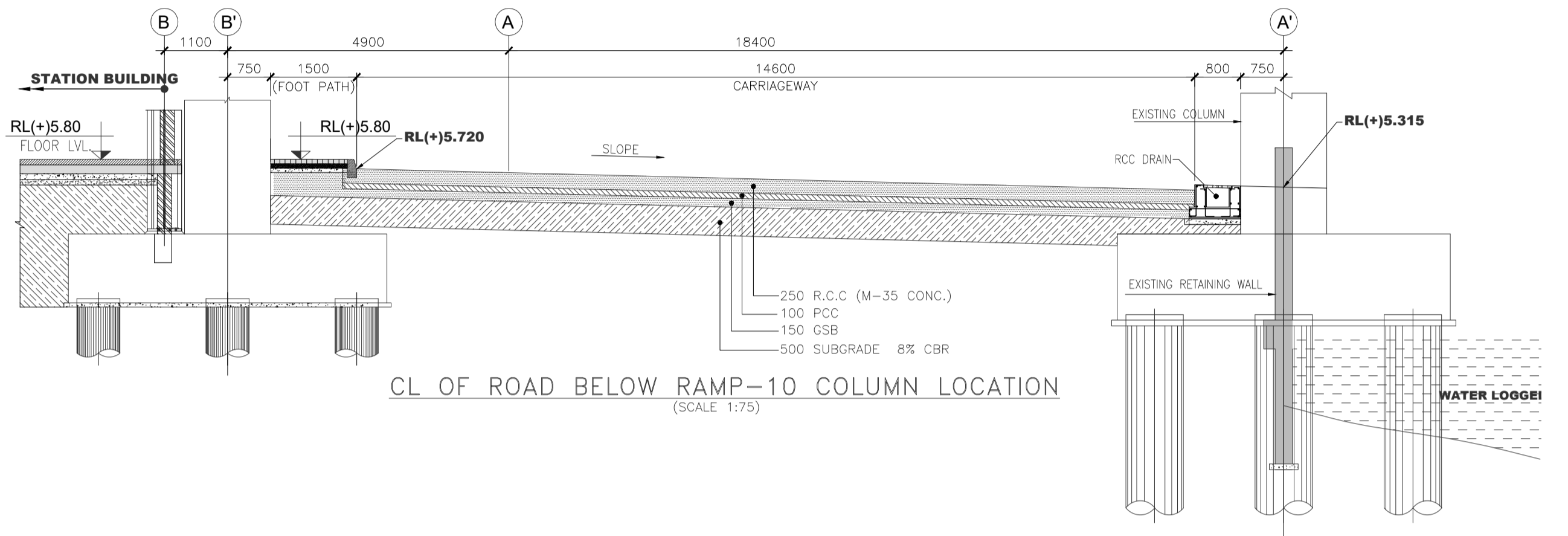

CL. OF ROAD BELOW RAMP-10 COLUMN LOCATION
(SCALE 1:75)

NOTES:

1. ALL DIMENSIONS ARE IN MM UNLESS NOTED OTHERWISE.
2. FOR DETAILS REFER IRC: 15-2011.
3. ALL REINFORCEMENT ARE FE500, EXCEPT DOWEL BARS. DOWEL BARS ARE FE 250
4. GRADE OF CONCRETE: PQC-M40, DLC-M15.
5. PAPER BACKING OF COMPRESSIBLE DEBONDING STRIP IS NOT NECESSARY IF THE STRIP IS NON-ABSORBANT TYPE.
6. JOINTS CAN BE SEALED BY ADOPTING ONE OF THE TWO OPTIONS OF DEBONDING STRIP/BACKER ROD AS SHOWN
7. DEPENDING UPON THE SEALANT MANUFACTURE'S RECOMMENDATION, THE SIDES OF THE GROOVE MAY HAVE TO BE SAND BLASTED/SAND PAPERED AND PRIMED.
8. THE GROOVE AND SEALANT DIMENSIONS SHOWN ARE ONLY FOR GUIDANCE
9. BACKER ROD/BACK UP ROD SHALL BE EXPANDED CLOSE CELL POLYTHENE FOAM.
10. ENDS OF THE SEALING GROOVE SHALL BE PLUGGED BEFORE POURING SEALANT TO AVOID SPILLAGE LATERALLY
11. THIS DRAWING SHOULD BE READ IN CONJUNCTION WITH DRG.NO. 9434/E/DD/TPR-1001

GOOD FOR CONSTRUCTION

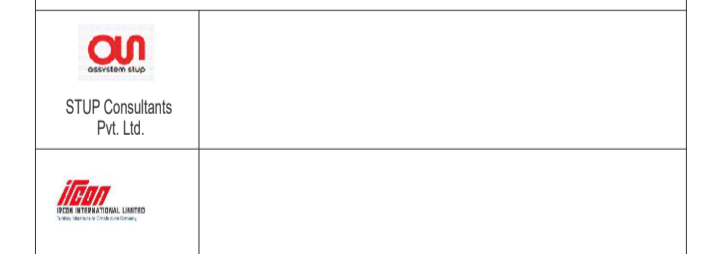

OWNER	SOUTH EASTERN RAILWAY		
PROJECT	SANTRAGACHI STATION DEVELOPMENT PROJECT (SOUTH EASTERN RAILWAY)		
TITLE	DETAIL OF RIGID PAVEMENT FOR AT GRADE PATHWAY		

SCALE	AS NOTED	EXECUTING AGENCY:-	
DRAWN	K.G	IRCON INTERNATIONAL LIMITED (A Govt. of India Undertaking) C-4, District Centre Soket, New Delhi-110017 Tel: +91-29565666, Fax: +91-26522000/2685400 E-mail: info@ircon.org, web:ircon.org.	
CHECKED	AD	STUP Consultants P. Ltd.	
APPROVED	SMS	REGISTERED OFFICE: Unit No. 2702, 27th Floor, Rupa Renaissance, Plot No. D-33 & D-207, Jangpore MIDC TTC Industrial Area, Turbhe, Navi Mumbai, Thane, Maharashtra-400703	
DRG. NO.	9434/E/DD/RD-4544 (SHT. 1 OF 1)	DATE	31.05.2024
REV.	RO	DRN.	
REV.		CHD.	
REV.		APPR.	
REV.		DATE	

REV.	PARTICULARS	DRN.	CHD.	APPR.	DATE
------	-------------	------	------	-------	------